

# TM 11-7025-234-23

## ORGANIZATIONAL AND DIRECT SUPPORT MAINTENANCE MANUAL

### MODEM UNIT MD-1149/MYQ-4A

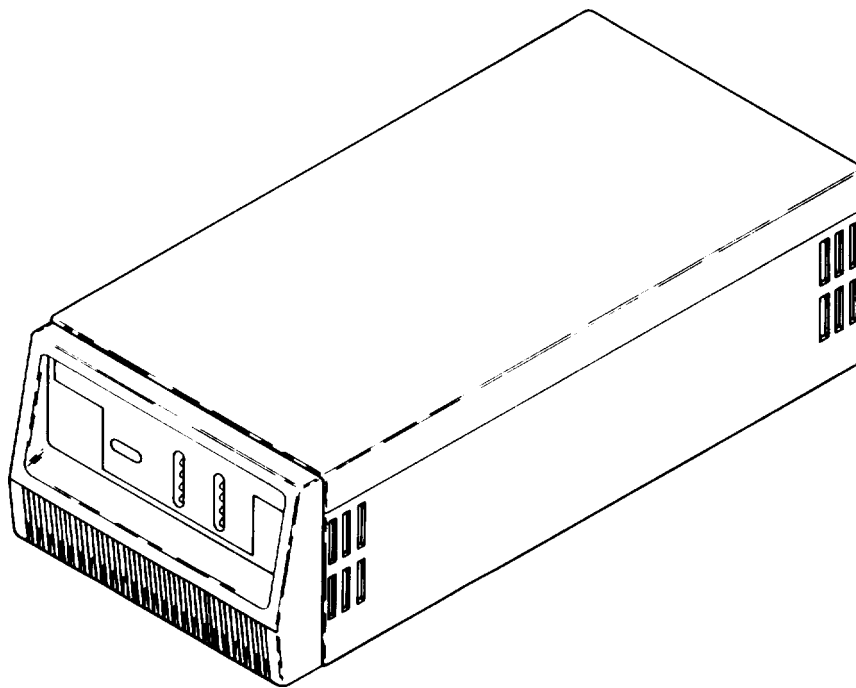

PMCS  
PAGE 3-2

TROUBLESHOOTING  
PAGE 4-1

(NSN 5805-01-126-2021)

HEADQUARTERS DEPARTMENT OF THE ARMY

2 MAY 1985

## **WARNING**

HIGH VOLTAGE

is used in the operation of this equipment

ELECTROCUTION

may result if personnel fail to observe safety precautions.

Never work on electronic equipment unless there is another person nearby. He/she should be familiar with the operation and hazards of the equipment. He/she should also be competent in giving first aid. When you are helped by operators, you must warn them about dangerous areas.

Whenever possible, the power supply to the equipment must be shut off before beginning work on the equipment. Take special care to ground every capacitor likely to hold a dangerous potential. When working inside the equipment, after the power has been turned off, always ground every part before touching it.

Be careful not to contact high-voltage connections when installing or operating this equipment.

Whenever possible, keep one hand away from the equipment to reduce the hazard of current flowing through vital organs of the body.

## **WARNING**

Do not be misled by the term "low voltage". Voltages as low as 50 volts may cause death.

For artificial respiration, refer to FM 21-11.

## **WARNING**

Remove rings, bracelets, wristwatches, and neck chains before working around electronic equipment. Jewelry can catch on equipment and cause injury, or may short across an electrical circuit and cause severe burns or electrical shock.

**5**

SAFETY STEPS TO FOLLOW IF SOMEONE  
IS THE VICTIM OF ELECTRICAL SHOCK

**1**

DO NOT TRY TO PULL OR GRAB THE INDIVIDUAL

**2**

IF POSSIBLE , TURN OFF THE ELECTRICAL POWER

**3**

IF YOU CANNOT TURN OFF THE ELECTRICAL  
POWER, PULL, PUSH, OR LIFT THE PERSON TO  
SAFETY USING A WOODEN POLE OR A ROPE OR  
SOME OTHER INSULATING MATERIAL

**4**

SEND FOR HELP AS SOON AS POSSIBLE

**5**

AFTER THE INJURED PERSON IS FREE OF  
CONTACT WITH THE SOURCE OF ELECTRICAL  
SHOCK, MOVE THE PERSON A SHORT DISTANCE  
AWAY AND IMMEDIATELY START ARTIFICIAL  
RESUSCITATION



**ORGANIZATIONAL AND DIRECT SUPPORT MAINTENANCE MANUAL**

**MODEM UNIT MD-1 149/MYQ-4A**

REPORTING ERRORS AND RECOMMENDING IMPROVEMENTS

You can help improve this manual. **If** you find any mistakes or if you know of a way to improve the procedures, please let us know. Mail your letter, DA Form 2028 (Recommended Changes to Publications and Blank Forms), or DA Form 2028-2 located in back of this manual, direct to: Commander, US Army Communications and Electronics Command and Fort Monmouth, ATTN: DRSEL-ME-MP, Fort Monmouth, New Jersey 07703. A reply will be furnished to you.

		Page
	HOW TO USE THIS MANUAL . . . . .	v
CHAPTER 1	INTRODUCTION. . . . .	1-1
Section I	<u>General Information . . . . .</u>	1-1
Section II	<u>Equipment Description and Data . . . . .</u>	1-3
CHAPTER 2	TECHNICAL PRINCIPLES OF OPERATION . . . . .	2-1
CHAPTER 3	ORGANIZATIONAL MAINTENANCE INSTRUCTIONS . . . . .	3-1
Section I	Repair Parts, Special Tools, TMDE, and Support Equipment . . . . .	3-1
Section II	Service Upon Receipt . . . . .	3-1
Section III	<u>Preventive Maintenance Checks and Services . . . . .</u>	3-2
CHAPTER 4	DIRECT SUPPORT MAINTENANCE INSTRUCTIONS . . . . .	4-1
Section I	Repair Parts, Special Tools, TMDE, and Support Equipment . . . . .	4-1
Section 11	<u>Troubleshooting . . . . .</u>	4-1
Section 111	<u>Maintenance Procedures . . . . .</u>	4-8
APPENDIX A	REFERENCES. . . . .	A-1
APPENDIX B	MAINTENANCE ALLOCATION CHART . . . . .	B-1
APPENDIX C	EXPENDABLE SUPPLIES AND MATERIALS LIST . . . . .	C-1
APPENDIX D	SCHEMATIC DIAGRAMS. . . . .	D-1
	GLOSSARY. . . . .	Glossary-1
	INDEX . . . . .	Index-1



## HOW TO USE THIS MANUAL

This manual tells you how to troubleshoot and maintain Modem Unit MD-1149/MYQ-4A.

### LOCATION OF SUBJECTS IN MANUAL

In this manual, paragraphs are numbered in order by chapter. For example, paragraph 2-3 is the third paragraph in chapter 2. Pages are also numbered this way. Using this numbering system, there are three easy ways to locate the information you need in this manual.

- Front cover locators
- Alphabetical index
- Index of maintenance procedures

Use the front cover locators and marked pages to quickly find the parts of the manual shown on the cover. These locators mark portions of the manual which are used often. If the information you need is not listed on the front cover, use the alphabetical index at the back of this manual. It lists all subjects covered in the manual and directs you to the subject by paragraph number. When you need a specific maintenance procedure, use the index at the start of chapter 3 or 4. This index lists all the maintenance procedures in the chapter and directs you to each procedure by page number.

### MAINTENANCE PROCEDURES

Maintenance procedures in this manual have two features which help you perform them more easily:

- Initial setup boxes
- First-time performance aids

An initial setup box is used at the start of any procedure which requires setup items before you perform it. This box lists items needed to perform the procedure. **If** the box does not appear at the start of a procedure, no setup items are needed.

**If** you are using this manual to perform a procedure for the first time, always read through the entire procedure before you start. Always perform the task steps in the order given. This will help assure correct performance. Use the illustrations beside the task steps to find the parts of the equipment called out in the steps. Some steps include a reference to another paragraph. Go to that paragraph if you are not sure how the step is done.

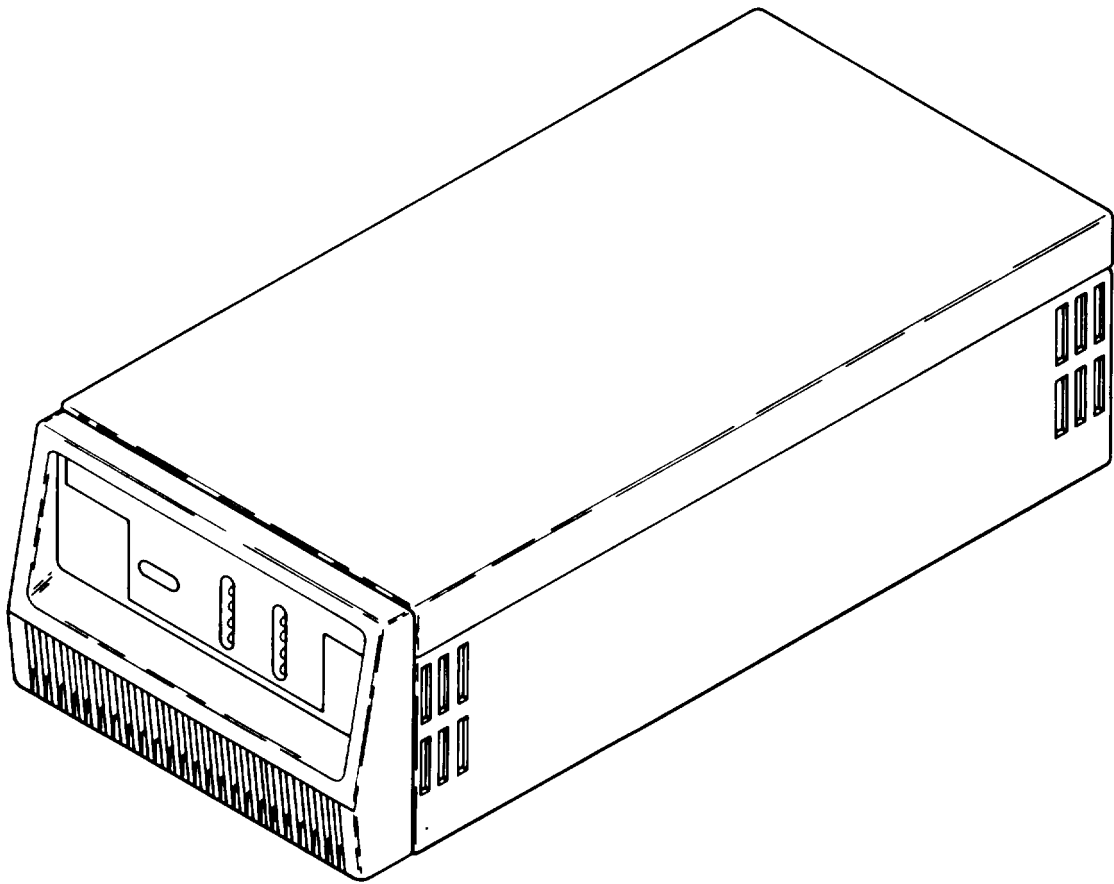

Figure 1-0. Modem Unit MD-1149/MYQ-4A



# CHAPTER 1 INTRODUCTION

## Section 1. GENERAL INFORMATION

### 1-1. SCOPE

Modem Unit MD-1149/MYQ-4A (fig. 1-0) provides signal conversion capability required to transmit data from one data processing system to another. In the rest of this manual, it will be called the V.29 modem; Use this manual for organizational and direct support maintenance of the V.29 modem.

### 1-2. INDEX OF PUBLICATIONS

Refer to the latest issue of DA PAM 310-1 to determine whether there are new editions, changes or additional publications pertaining to the modem assembly.

### 1-3. MAINTENANCE FORMS, RECORDS, AND REPORTS

Department of the Army forms and procedures used for equipment maintenance will be those prescribed by TM 38-750, The Army Maintenance Management System (TAMMS).

### 1-4. DESTRUCTION OF ARMY ELECTRONICS MATERIEL

Destruction of Army electronics materiel to prevent enemy use shall be in accordance with TM 750-244-2.

### 1-5. ADMINISTRATIVE STORAGE

Administrative storage of equipment issued to and used by Army activities will have Preventive Maintenance Checks and Services (PMCS) performed before storing. When removing the equipment from administrative storage, the PMCS checks should be performed to assure operational readiness. Disassembly and repacking of equipment for limited storage are covered in TM 740-90-1.

### 1-6. REPORTING EQUIPMENT IMPROVEMENT RECOMMENDATIONS (EIR)

If your V.29 modem needs improvement, let us know. Send us an EIR. You, the user, are the only one who can tell us what you don't like about your equipment. Let us know why you don't like the design or performance. Put it on an SF 368 (Quality Deficiency Report). Mail it to us at Commander, U. S. Army Communications and Electronics Command and Fort Monmouth, ATTN: DRSEL-ME-MP, Fort Monmouth, NJ 07703. We'll send you a reply.

1-7. REFERENCE INFORMATION

This listing includes the nomenclature cross reference list, the list of abbreviations and an explanation of terms (glossary) used in this manual.

1-8. NOMENCLATURE CROSS REFERENCE LIST

Common names are used throughout this manual, but you must use the official nomenclature when filling out report forms, sending an EIR, or finding referenced technical manuals.

<u>Common Name</u>	<u>Official Nomenclature</u>
V. 29 Modem or modem assembly	Modem Unit MD-1149/MYQ-4A

1-9. LIST OF ABBREVIATIONS

ADP	Automated data processing
AGC	Automatic gain control
CCITT	Consultive committee on international telephone and telegraph
CPU	Central processing unit
DAA	Data access arrangement
dBm	Decibels referred to one milliwatt
DCE	Data communications equipment
DSR	Data set ready
DTE	Data terminal equipment
EIA	Electronic industries association
EQM	Eye quality monitor
ERR	Error
Hz	Hertz
I/O	Input/Output
LSI	Large scale integration
MDM	Modem
MHz	Megahertz
ms	Milliseconds
MODEM	Modulator-demodulator
	ON/OFF hook
QAM	Quadrature amplitude modulation
RAM	Random access' memory
REC	Receiver
RLB	Remote loopback
TP	Test point
X MT	Transmitter

1-10. GLOSSARY

A complete glossary of unusual terms is given in the back of this manual (Glossary-1).

## Section II. EQUIPMENT DESCRIPTION AND DATA

### 1-11. EQUIPMENT PURPOSE, CAPABILITIES AND FEATURES

The V.29 modem conforms to EIA RS-232C (CCITT V.24) recommendation V.29 and is designed for use in both point-to-point and multipoint configurations over 4-wire dedicated lines. The V.29 modem can:

- Receive and transmit information between one ADP System and other ADP systems or remote terminals
- Process 9600 bps of serial synchronous digital input data for transmission at a 2400, 1600, or 1200 baud rate
- Continue to update 2400 times per second, (1600 times per second when a 1600 baud rate is selected) in a completely unattended data mode
- **Scramble input data before transmission to prevent receiver from becoming sensitive to data patterns.**
- Operate at 9600 bps or when deterioration conditions exist, drop to 7200 or 4800 bps

a. Data and Signaling Rates. The data rate of the V.29 modem unit is 9600 bits per second (bps) of serial, synchronous, binary data with a fallback capability to 7200, 4800, or 2400 bps. The V.29 modem has a 2400 baud line signaling rate utilizing double side band, suppressed carrier, quadrature amplitude modulation (QAM). Also available is a 4800 bps/1600 baud fallback mode and 2400 bps/1200 baud fallback mode. Receive timing synchronization, automatic gain control (AGC) setting, and equalization are maintained during line interruptions up to 10 seconds.

b. Transmit Output Level. The output level of the transmit output amplifier is switch-selectable to configure to a variety of applications. Level may be set at -16, -14, -12, -10, -8, -6, -4, or 0 dBm (fig. 1-6).

c. Receive Input Level. The receive input level sensitivity is -40 to 0 dBm.

d. Equalizer Setup Time. During modem operation, the equalizer function monitors the delay and amplitude characteristics of the data line, senses differences due to transmission line changes and adjusts the delay and amplitude accordingly. At 2400 baud the equalizer is set up within 253 ms; for 2400 baud operation (9600, 7200, or 4800 bps) it is setup within 275 ms; at 1600 baud (4800 bps) it is set up within 140 ms, and at 1200 baud (2400 bps) it is set up within 153 ms.

e. Internal HF Oscillator. A 3.6864 MHz crystal oscillator having a long term stability is used as a reference.

f. Telephone Line. The V.29 modem operates over 4-wire dedicated lines.

(1) In 2400 baud mode it requires a balanced 600-ohm, type 3002, C2 unconditioned telephone line or equivalent, with a normal 16 dBm loss and frequency translation of up to  $\pm 10$  Hz.

(2) In 1600 baud mode it requires a balanced 600-ohm, type 3002, unconditioned telephone line or equivalents, with a normal 16 dBm loss and frequency translation of up to  $\pm 10$  Hz.

g. Interface. Conforms to EIA RS-232C (CCITT V.24) low input and output interface and interface exchange.

1-12. LOCATION AND DESCRIPTION OF <b>MAJOR</b> COMPONENTS
---

Major operating components (figs. 1-1 and 1-2) are removable from the top of V.29 modem. To gain access, it is necessary to raise top cover assembly by unfastening two screw fasteners located on front of V.29 modem chassis behind the swing-down front panel.

- |                                |  |
|--------------------------------|--|
| ① Front Panel                  | Front panel swings down for access to diagnostic controls and indicators.        |
| ② Chassis                      | Outer shell containing all components of the modem.                              |
| ③ Screw Fasteners              | Two captive screws retaining the cover assembly.                                 |
| ④ Top Cover                    | Raises to provide access to circuit boards, strapping, and voltage adjustments.  |
| ⑤ 115 Volt ac Power Receptacle | Provides ac electrical input to the modem assembly using a removable power cord. |
| ⑥ Ground Post                  | Power ground, common to ground position on ac power receptacle.                  |
| ⑦ Power ON/OFF Switch          | Rocker type switch, controls ac power to V.29 modem.                             |

Figure 1-1. V.29 Modem External Components (1 of 2)

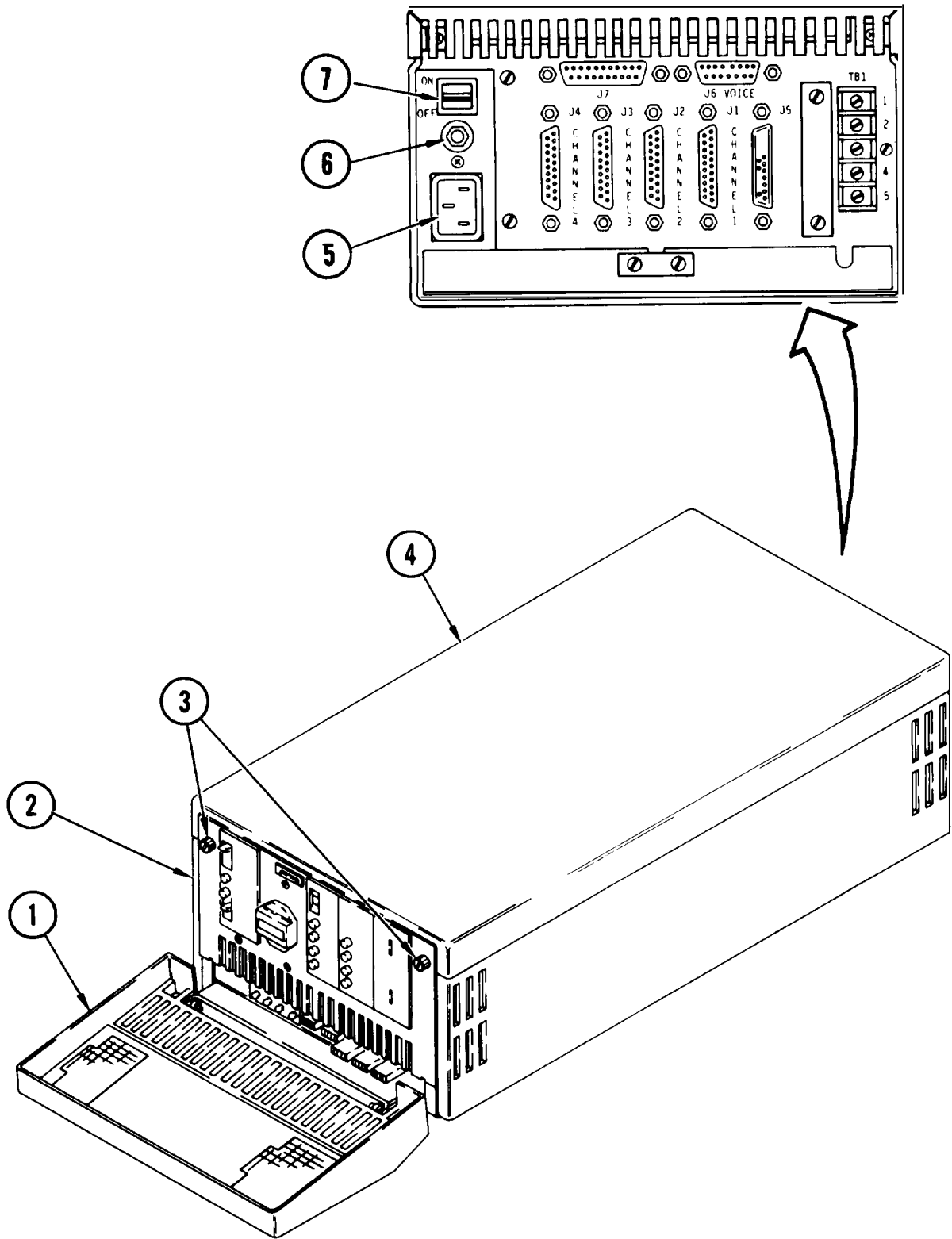

Figure 1-1. V.29 Modem External Components (2 of 2)

1-12. LOCATION AND DESCRIPTION OF MAJOR COMPONENTS (CONT)

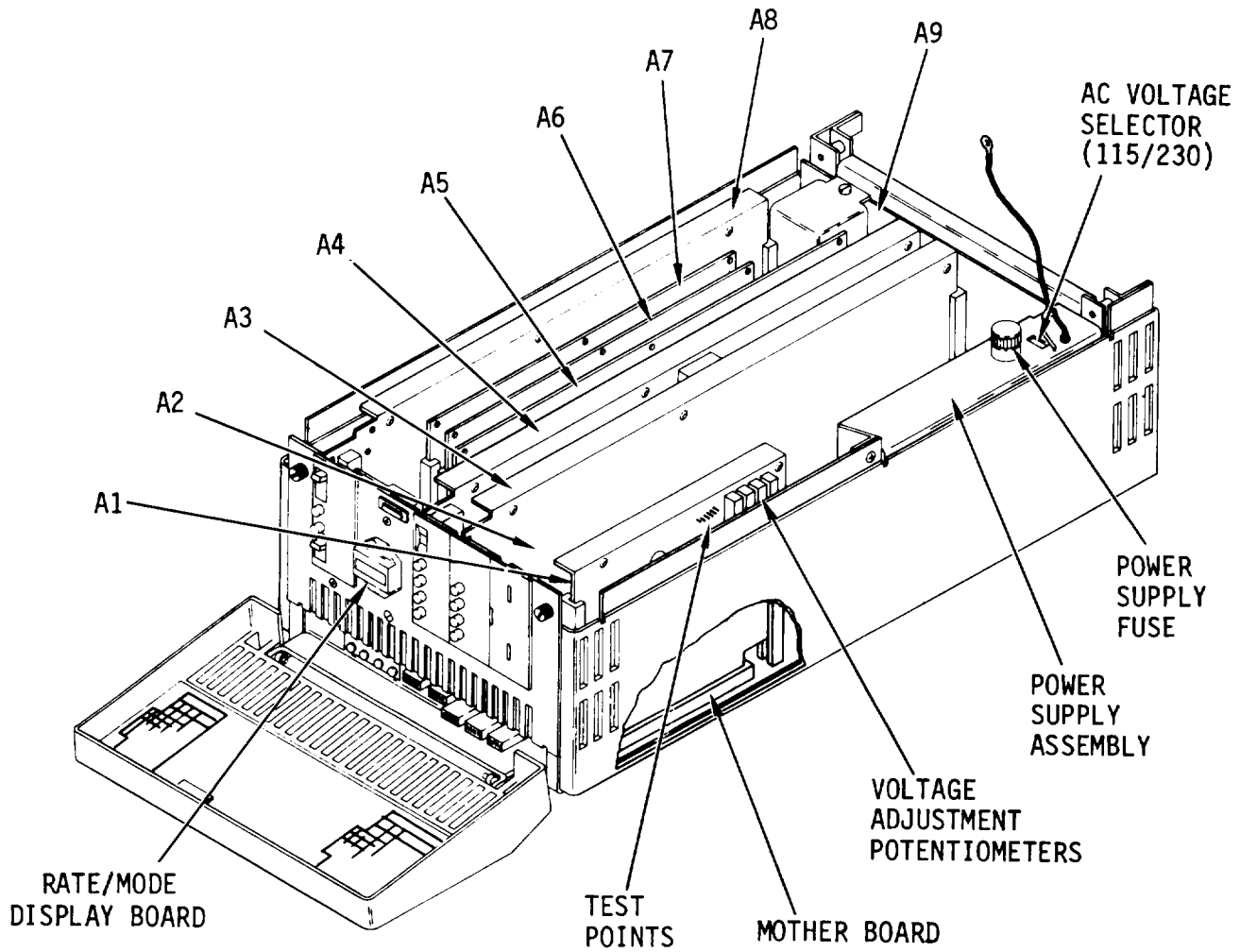

Figure 1-2. V.29 Modem Internal Components (1 of 2)

Ac Voltage Selector	Slide switch for selecting either 115 or 230 volt operation.
Fuse	Power supply fuse, 1/4 Amp.
Power Supply Assembly	Provides unregulated positive and negative voltages for the regulator board.
Mother Board	Provides hardware interface for circuit board components.
Voltage Adjust Potentiometers	Used to adjust voltages on the power supply regulator board (AI).
Test Points	Used to check voltages on the power supply regulator board (AI).
Rate/Mode Display Board	Provides LED display of data rate and operational mode.
AI Board	Power supply regulator board.
A2 Board	Not used in this model.
A3 Board	EIA interface board.
A4 Board	Control board.
A5 Board	Receiver board.
A6 Board	Receiver equalizer board.
A7 Board	Transmitter board.
A8 Board	Remote loopback board.
A9 Board	I/O board.

Figure 1-2. V.29 Modem Internal Components (2 of 2)

---

1-13. EQUIPMENT IDENTIFICATION PLATE

---

The V.29 modem identification plate (fig. 1-3) is on the top right corner.

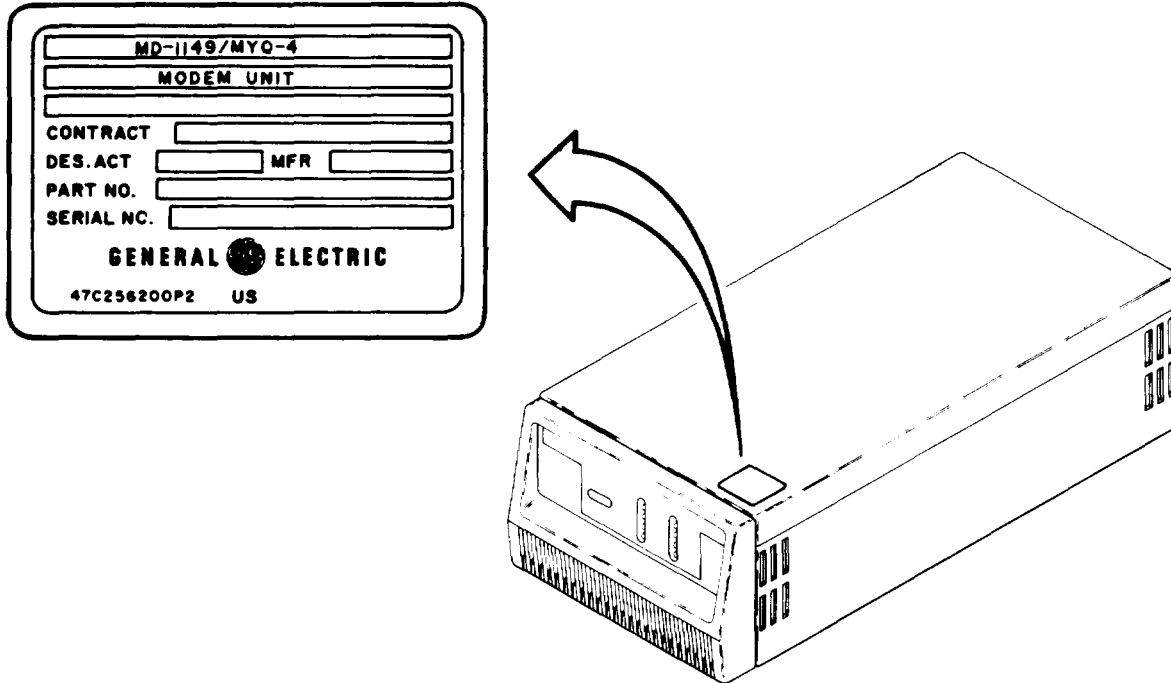

Figure 1-3. Equipment Identification Plate

---

1-14. EQUIPMENT DATA

---

Weight and dimensions:

Weight	15.0 lb	(6.8 kg)
Height	5.25 in.	(14.0 cm)
Width	8.50 in.	(22.0 cm)
Depth	18.0 in.	(46.0 cm)

Operating environment:

Temperature	32°F to 121°F	(0°C to 50°C)
Relative humidity	20% to 80% (noncondensing)	

Electrical requirements:

Voltage	115 or 230 V	ac±10%
Frequency	47 to 63 Hz	

1-15. EQUIPMENT CONFIGURATION

The V.29 modem configuration options include mounting, power, and modem board jumpering.



1-16. Modem Mounting Options. This modem may be operated either on a table top or in a single or double rack mount (fig. 1-4).

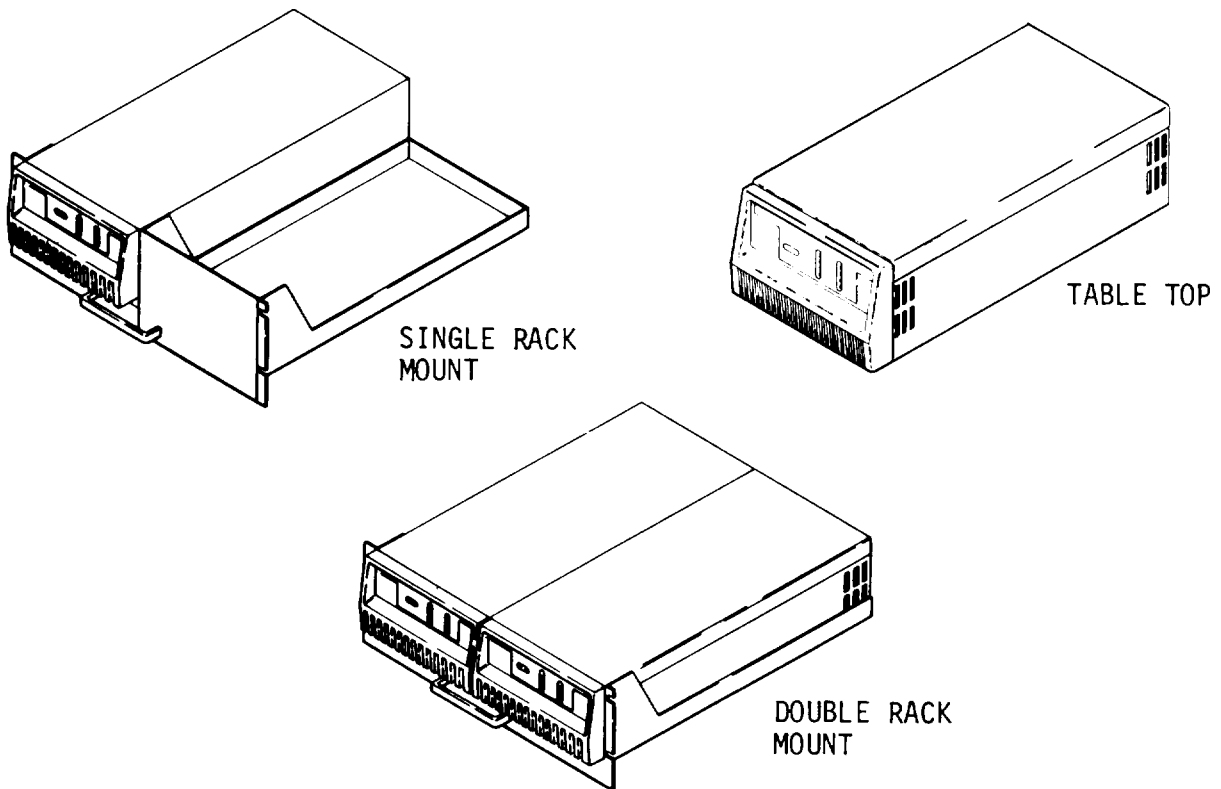

Figure 1-4. Mounting Options

#### 1-17. POWER OPTIONS

Ac power is supplied to the modem through a seven foot line cord with a grounded three prong plug. If chassis protective ground is connected through the third prong of the power plug, a separate ground wire is not required. A mother board strap permits connection of signal ground to protective ground (fig. 1-7). A two position switch on the power supply allows selection of either 115 or 230 V ac  $\pm 10\%$  single phase 47 to 63 Hz at 20 watts maximum power.

#### 1-18. MODEM BOARD JUMPER OPTIONS

Modem board configuration is changed by jumpers (fig. 1-5). Jumpers are located on the mother board, EIA Interface (A3), Control (A4), Remote Loopback (A8), Input/output (A9), and rate/mode display boards. Three types of jumpers are used:

- Dip switch jumpers - miniature rocker switches used to select applicable configurations. They are located on the top of circuit boards and accessible from the top of modem

- Plug jumpers - seldom changed jumpers are in the form of plug jumpers which require the board to be removed and a jumper added or deleted
- Patch or solder jumpers - wire jumpers used on the rear side of the I/O board

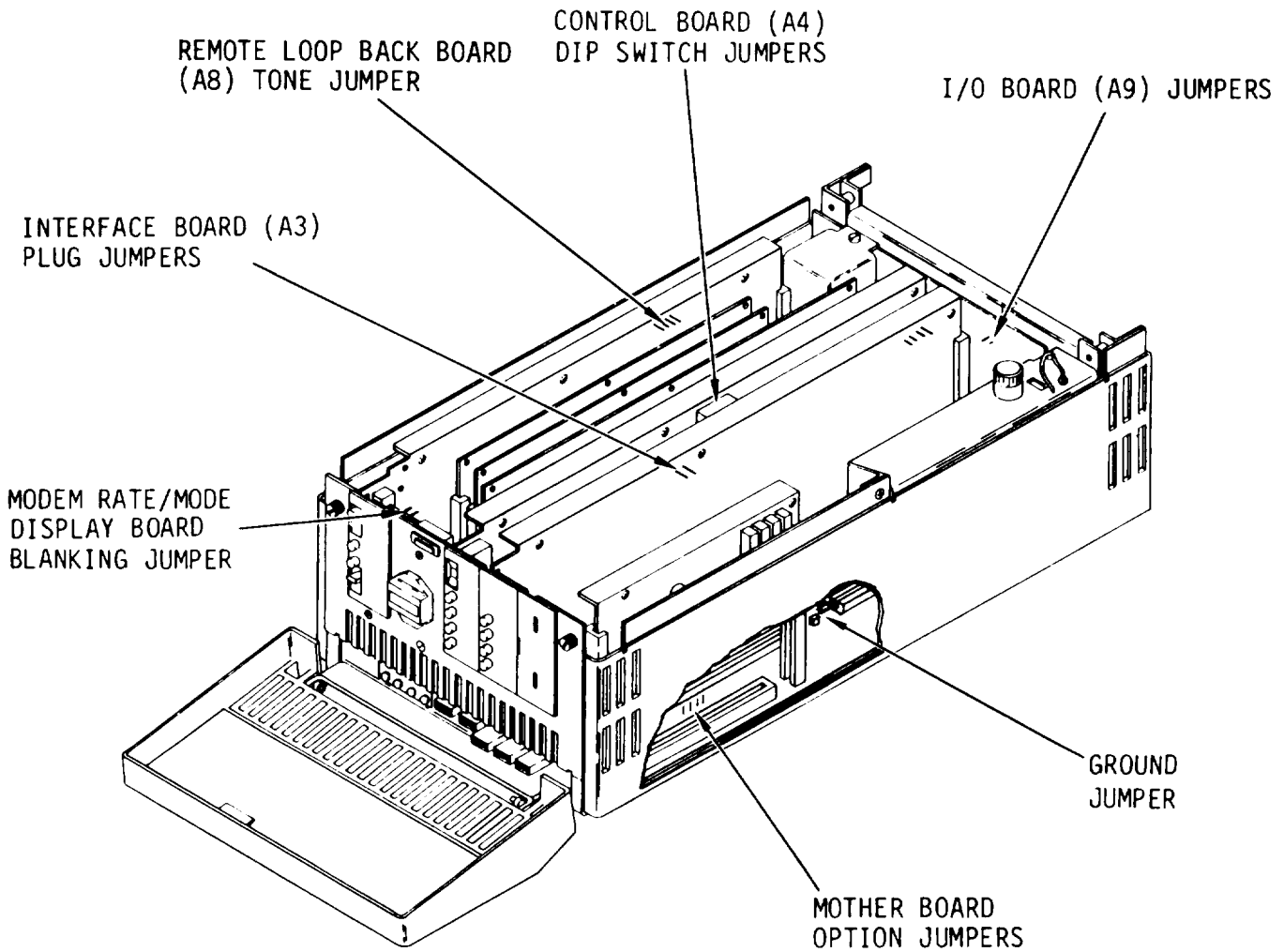

Figure 1-5. Jumper Locations

a. Mother Board Jumpers. The mother board can be jumpered to automatically shut down the dc voltages when a board is removed from the mother board connector while ac power is on.

(1) Shutdown Feature. The jumpers which cause the power supply to shut down upon removal of boards A3 or A4 are on EF and GH (fig. 1-7). These jumpers are placed on AB and CD to override the shut down feature for troubleshooting. However, they should be returned to EF and GH when the modem assembly is placed back into normal operation.

(2) Transmit Output Level Switch. The transmitter output signal level is controlled by a ten position screwdriver-adjustable switch located near board A7 (fig. 1-6). Position 0 terminates the transmit line in 600 ohms.

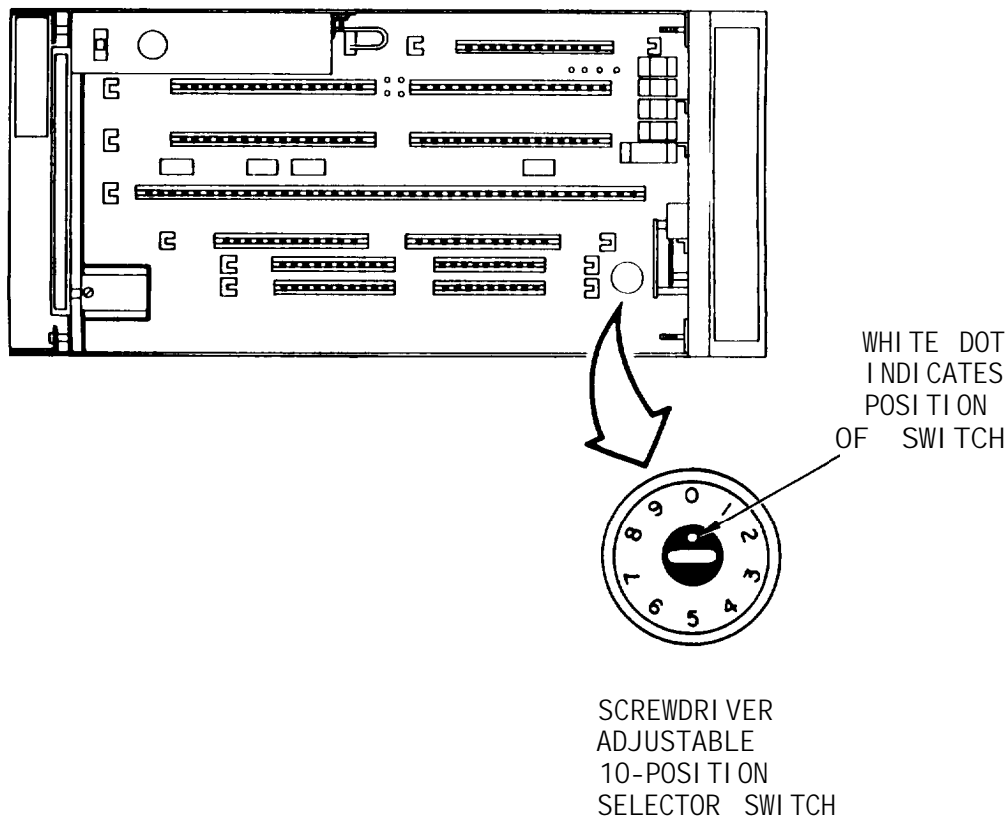

Figure 1-6. Transmit Output Level Switch

(3) Ground Jumper. A ground jumper (fig. 1-7) is provided to connect protective ground pin 1 to signal ground pin 7 J1 thru J4) to signal ground (AB pin 7 J1). This ground jumper is factory set as shown in figure 1-7 (AC to DC ground or Signal to Chassis Ground). The other terminal is used only when a ground fault is suspected or when ground has an unsatisfactory noise level.

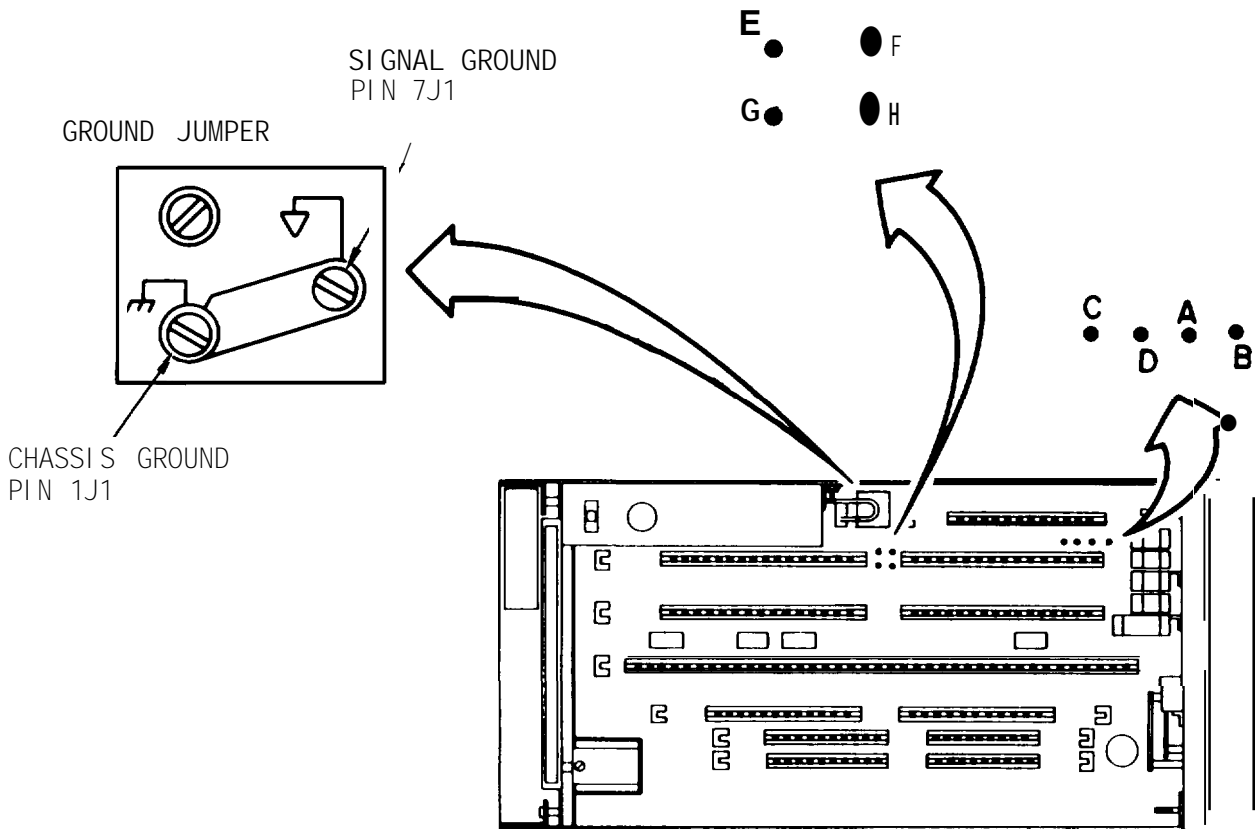

Figure 1-7. Location of Mother Board Jumpers

b. Interface Board (A3) Jumpers. Plug jumpers (fig. 1-8) are provided on board A3 to select CA/CB DELAY, CH/CI, or CB ON.

c. Control Board (A4) Jumpers. The control board jumpers (fig. 1-9) select the following:

- o Scrambler Selects
- o Master/Slave (Multipoint Mode Only)
- Transmit Timing
- Unattended Initiate
- o Modem Configuration

Table 1-1 identifies dip switch jumpers and explains their functions. Table 1-2 identifies plug jumpers and explains their functions.

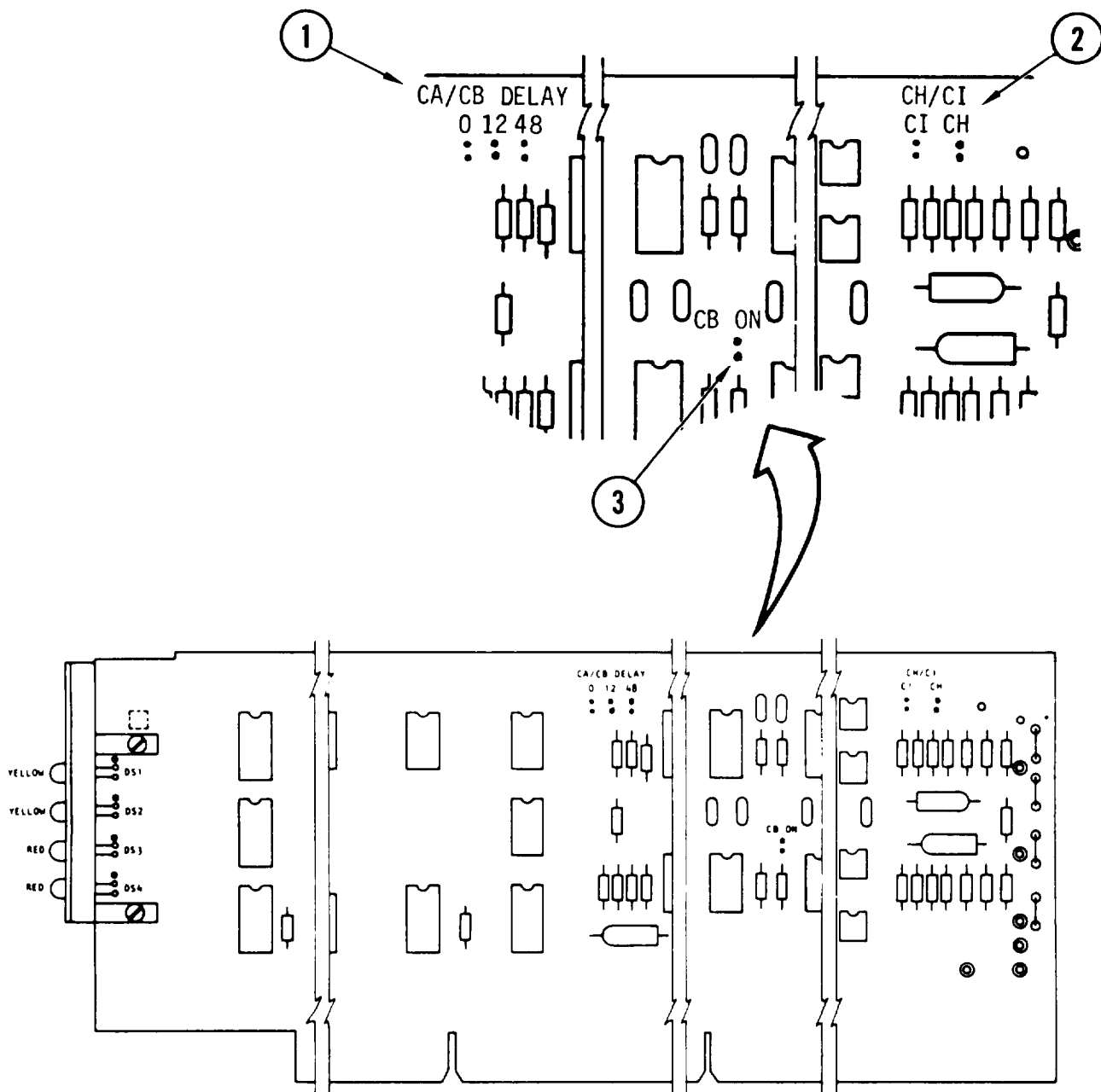

- ① A jumper-selectable turnaround delay of 0, 12, or 48 ms between receipt of Request to Send (CA) and Clear to Send (CB). Normally shipped with jumper 0.
- ② Data rate indication (CI) may be selected to allow the modem to indicate to the DTE the data rate. This is accomplished by positioning CI jumper in (CH jumper out). For external data rate control into the V.29 modem, position CH jumper in (CI jumper out). Normally shipped jumpered CI.
- ③ With the jumper in, CB is always on. Normally shipped with jumper out.

Figure 1-8. Interface Board (A3) Jumpers

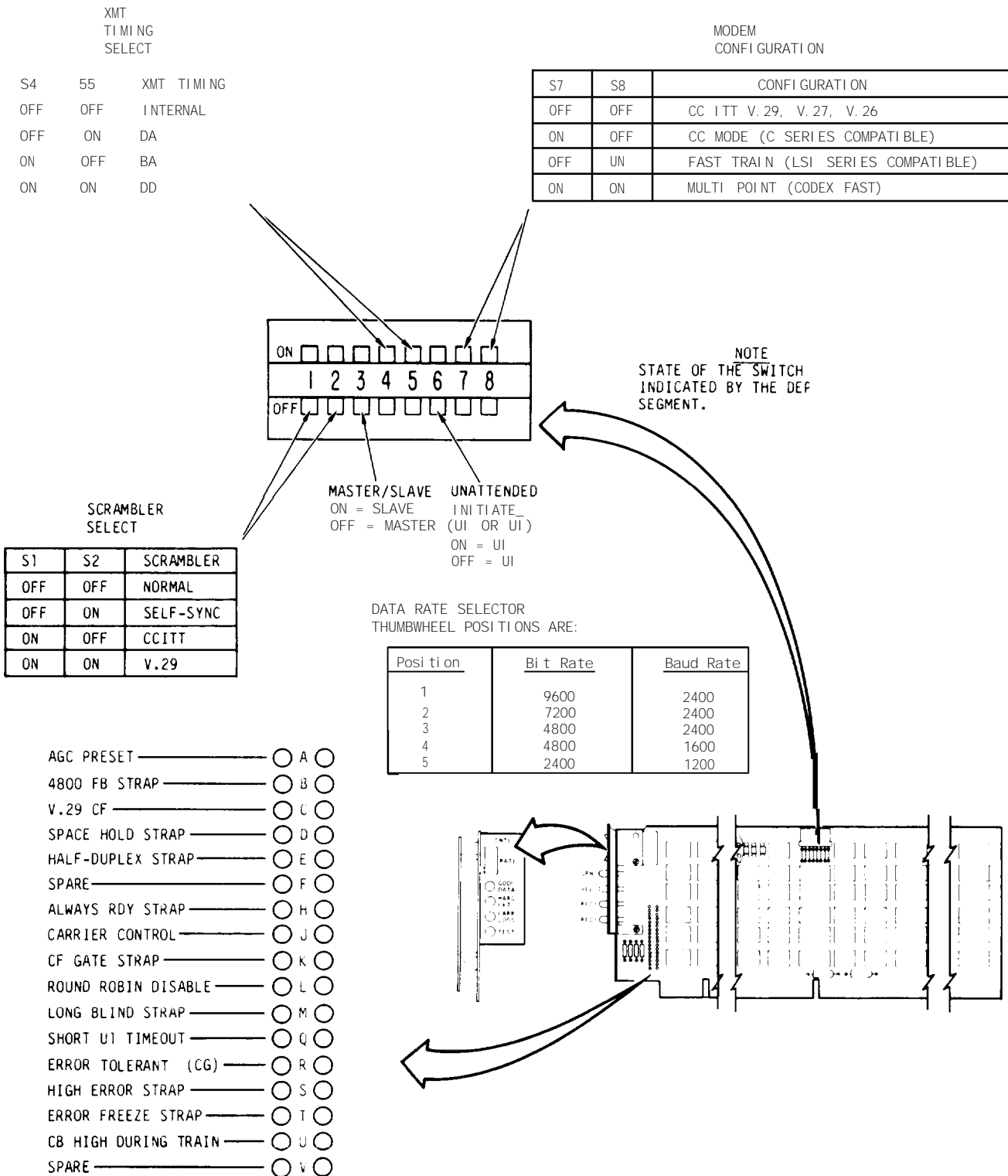

Figure 1-9. Control Board (A4) Jumpers and Dip Switch

Table 1-1. Control Board (A4) Dip Switch Jumpers

Jumper	Switch Position	Description															
Scrambler Select	<b>S1 &amp; S2</b>	<p>Selects one of four scramblers according to truth table below:</p> <table border="1"> <thead> <tr> <th><u>S1</u></th> <th><u>S2</u></th> <th><u>Scrambler</u></th> </tr> </thead> <tbody> <tr> <td>OFF</td> <td>OFF</td> <td>Normal</td> </tr> <tr> <td>OFF</td> <td>ON</td> <td>Self-Sync</td> </tr> <tr> <td>ON</td> <td>OFF</td> <td>CCITT</td> </tr> <tr> <td>ON</td> <td>ON</td> <td>V. 29 (Auto Selected in V. 29 Mode)</td> </tr> </tbody> </table>	<u>S1</u>	<u>S2</u>	<u>Scrambler</u>	OFF	OFF	Normal	OFF	ON	Self-Sync	ON	OFF	CCITT	ON	ON	V. 29 (Auto Selected in V. 29 Mode)
<u>S1</u>	<u>S2</u>	<u>Scrambler</u>															
OFF	OFF	Normal															
OFF	ON	Self-Sync															
ON	OFF	CCITT															
ON	ON	V. 29 (Auto Selected in V. 29 Mode)															
Master/Slave (Multi point Mode Only)	<b>S3</b>	<p>OFF = Master ON = Slave*</p> <p>*S3 ON selects a slave modem when S7 and S8 select multi point configuration.</p>															
Transmit Timing	<b>S4 &amp; S5</b>	<p>This set of jumpers provides four choices for transmit timing: internal, DA, BA, and DD as shown below:</p> <table border="1"> <thead> <tr> <th><u>S4</u></th> <th><u>S5</u></th> <th><b>Timing</b></th> </tr> </thead> <tbody> <tr> <td>OFF</td> <td>OFF</td> <td>(INT) Internal Oscillator</td> </tr> <tr> <td>OFF</td> <td>ON</td> <td>(DA) External Clock Source</td> </tr> <tr> <td>ON</td> <td>OFF</td> <td>(BA) External Data Source</td> </tr> <tr> <td>ON</td> <td>ON</td> <td>*(DD) Loopback Timing</td> </tr> </tbody> </table> <p>*INTERNAL is forced for Modem Check or Audio Busback. (Local Loopback)</p>	<u>S4</u>	<u>S5</u>	<b>Timing</b>	OFF	OFF	(INT) Internal Oscillator	OFF	ON	(DA) External Clock Source	ON	OFF	(BA) External Data Source	ON	ON	*(DD) Loopback Timing
<u>S4</u>	<u>S5</u>	<b>Timing</b>															
OFF	OFF	(INT) Internal Oscillator															
OFF	ON	(DA) External Clock Source															
ON	OFF	(BA) External Data Source															
ON	ON	*(DD) Loopback Timing															
Unattended Initiate	<b>S6</b>	<p>S6 = OFF gives UI or unattended initiate capability based on signal quality.</p> <p>S6 = ON gives <math>\overline{UI}</math> or no UI capability.</p>															
Modem Configuration	<b>S7 &amp; S8</b>	<table border="1"> <thead> <tr> <th><u>S8</u></th> <th><b>S7</b></th> <th><u>Configuration</u></th> </tr> </thead> <tbody> <tr> <td>OFF</td> <td>OFF</td> <td>V. 29, V. 27, V. 26 Mode</td> </tr> <tr> <td>OFF</td> <td>ON</td> <td>CC Mode (C Series Modem Compatible)</td> </tr> <tr> <td>ON</td> <td>OFF</td> <td>Fast Train Mode (LSI Series Modem Compatible)</td> </tr> <tr> <td>ON</td> <td>ON</td> <td>Multi point*</td> </tr> </tbody> </table> <p>*S3 <b>ON</b> selects a slave modem.</p>	<u>S8</u>	<b>S7</b>	<u>Configuration</u>	OFF	OFF	V. 29, V. 27, V. 26 Mode	OFF	ON	CC Mode (C Series Modem Compatible)	ON	OFF	Fast Train Mode (LSI Series Modem Compatible)	ON	ON	Multi point*
<u>S8</u>	<b>S7</b>	<u>Configuration</u>															
OFF	OFF	V. 29, V. 27, V. 26 Mode															
OFF	ON	CC Mode (C Series Modem Compatible)															
ON	OFF	Fast Train Mode (LSI Series Modem Compatible)															
ON	ON	Multi point*															

Table 1-2. Control Board (A4) Plug Jumpers

Name	Jumper	Normal Configuration	Description																														
AGC Preset	A	OUT	With jumper out, AGC is preset to -38 dBm. With jumper in, AGC is preset to -24 dBm.																														
Fallback Rate	B	OUT	With jumper in, CH fallback is 4800 bps (2400 baud) for a 9600 modem. With jumper out, fallback is 7200 bps (2400 baud). The RATE switch affects the fallback rate as shown below:																														
			<table border="1"> <thead> <tr> <th></th> <th>RATE Switch</th> <th>Data Rate</th> <th>Control Card Jumper OUT</th> <th>Control Card Jumper B IN</th> </tr> </thead> <tbody> <tr> <td></td> <td>1</td> <td>96</td> <td>72</td> <td>48/24</td> </tr> <tr> <td></td> <td>2</td> <td>72</td> <td>48/24</td> <td>48/24</td> </tr> <tr> <td></td> <td>3</td> <td>48/24</td> <td>48/24</td> <td>48/24</td> </tr> <tr> <td></td> <td>4</td> <td>48/16</td> <td>48/16</td> <td>24/12</td> </tr> <tr> <td></td> <td>5</td> <td>24/12</td> <td>24/12</td> <td>24/12</td> </tr> </tbody> </table>		RATE Switch	Data Rate	Control Card Jumper OUT	Control Card Jumper B IN		1	96	72	48/24		2	72	48/24	48/24		3	48/24	48/24	48/24		4	48/16	48/16	24/12		5	24/12	24/12	24/12
	RATE Switch	Data Rate	Control Card Jumper OUT	Control Card Jumper B IN																													
	1	96	72	48/24																													
	2	72	48/24	48/24																													
	3	48/24	48/24	48/24																													
	4	48/16	48/16	24/12																													
	5	24/12	24/12	24/12																													
Inhibit A	C	OUT	With jumper in, the normal CF drop (when the modem is in receive train mode) is inhibited. Thus, CF follows carrier detect. Inhibit A is automatically in effect when the modem is in the V.29 mode.																														
Space Hold	D	OUT	With jumper in, the receive data is clamped to an EIA Space when CF is OFF. With jumper out, it is clamped to a Mark.																														
Half-Duplex	E	OUT	With jumper in, CA ON forces CF OFF.																														
Spare	F																																
Always CC	H	OUT	With jumper in, CC is always ON.																														
Carrier Control	J	OUT	With jumper in, carrier is controlled by CA and training is initiated on every rising edge of CA. With jumper out, carrier is always ON unless configured as a multipoint slave.																														
CF Gate Jumper	K	OUT	With jumper in, DD is disabled when CF is OFF.																														



Table 1-2. Control Board (A4) Plug Jumpers -- Continued

Name	Jumper	Normal Configuration	Description
Round Robin Disable	L	OUT	With jumper in, round robin training is disabled.
Long Blind	M	OUT	With jumper in, the blind interval used to inhibit endless loops in the round robin training discipline is doubled. This jumper would be used in long path delay channels as satellite.
Short UI Timeout	Q	OUT	With jumper in, UI timeout is 1.7 sec. With jumper out, UI timeout is 6.8 sec at the 2400 baud rate.
High Threshold CG	R	OUT	With jumper in, CG turns off at an error rate of approximately $1 \times 10^{-3}$ . With jumper out, threshold is approximately $1 \times 10^{-4}$ .
High Error Jumper	S	OUT	With jumper in, all signal quality thresholds including UI, CG, and quality indicators are increased about an order of magnitude in error rate over normal.
High Error Freeze	T	OUT	With jumper in, equalizer taps and receive timing recovery updates are frozen and thus not allowed to update under high error rate conditions.
CB Low During Train	U	OUT	With jumper out, CB drops during training and follows CA. With jumpers in, CB follows CA dependent on CA/CB delay, but does not drop during training or test mode.
Spare	V		

d. Remote Loopback Board (A8) Jumpers. A remote dc loopback is initiated by sending a 1.92 kHz tone to the remote site. A remote audio loopback is initiated by sending a 2.4 Hz tone. The transmit carrier is off while tone is sent. Sending both tones simultaneously clears the loopback. The duration of time the tones are sent for each of the three commands is determined by a plug jumper. This jumper (fig. 1-10) will normally be in the 2.13 second position.

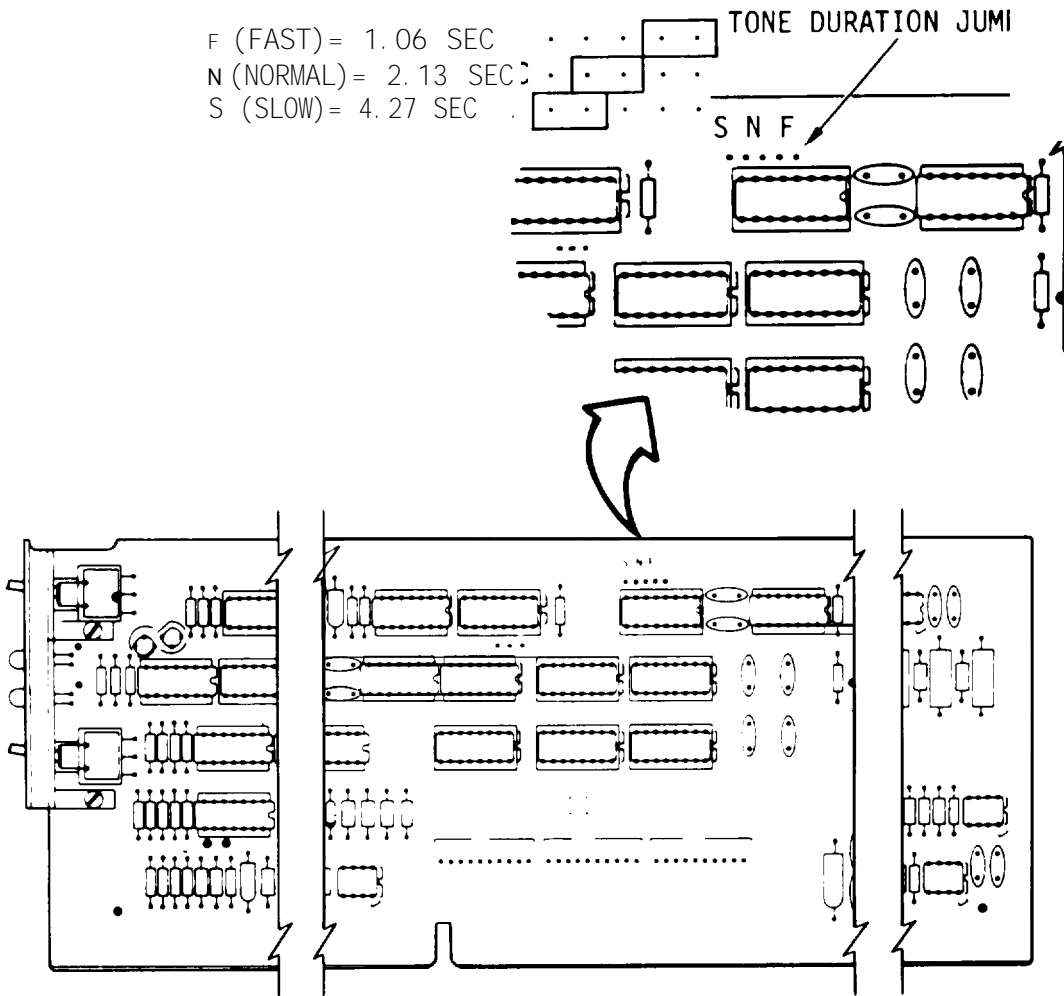

Figure 1-10. Remote Loopback Board (A8) Plug Jumper

e. Rear Panel I/O Board (A9) Jumpers. The domestic rear panel and associated connectors (fig. 1-11) are part of a plug-in circuit board assembly which installs in modem board slot A9. J1, a 25-pin connector, is the standard interface connector supplying input/output data, control, status, and timing interface signals between the modem and the data terminal equipment. J2 thru J4 are identical to J1 and are used for channels 2 thru 4 of the multiplexer option. J5, a 25-pin connector, is normally used to terminate the telephone transmit and

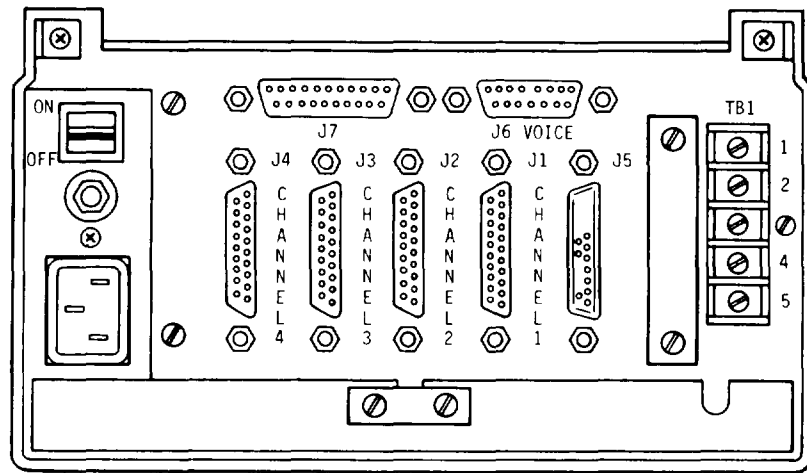

Figure 1-11. Domestic I/O Board (A9), Rear Panel Connectors

receive lines. A cable assembly is provided to connect J5 to the telephone lines. J6 is a 15-pin connector, provided for use with the Alternate Voice/Data. J7 is used for secondary channel interface connection. The red and green wires connect to the V.29 modem transmitter output, and the yellow and black wires connect to the V.29 modem's receiver input. Terminal board 1 has five screw terminals which may also be used for connecting the telephone lines if desired. Figure 1-12 illustrates the I/O interface cabling. The interface is compatible with EIA RS-232C and (CCITT V.24) low level input/output interface and interface exchange requirements. Table 1-3 lists and describes each interface signal. There is one active component on the domestic I/O board, an operational amplifier in the transmit audio path, which provides transmit pre-emphasis and a selectable 1 dB lowering of the transmit level capability. The two audio line transformers are also mounted to the I/O board and interface to it. There is a series of patch or solder jumpers (fig. 1-13) provided on the I/O board which are accessible on the solder side. These are described in table 1-4.

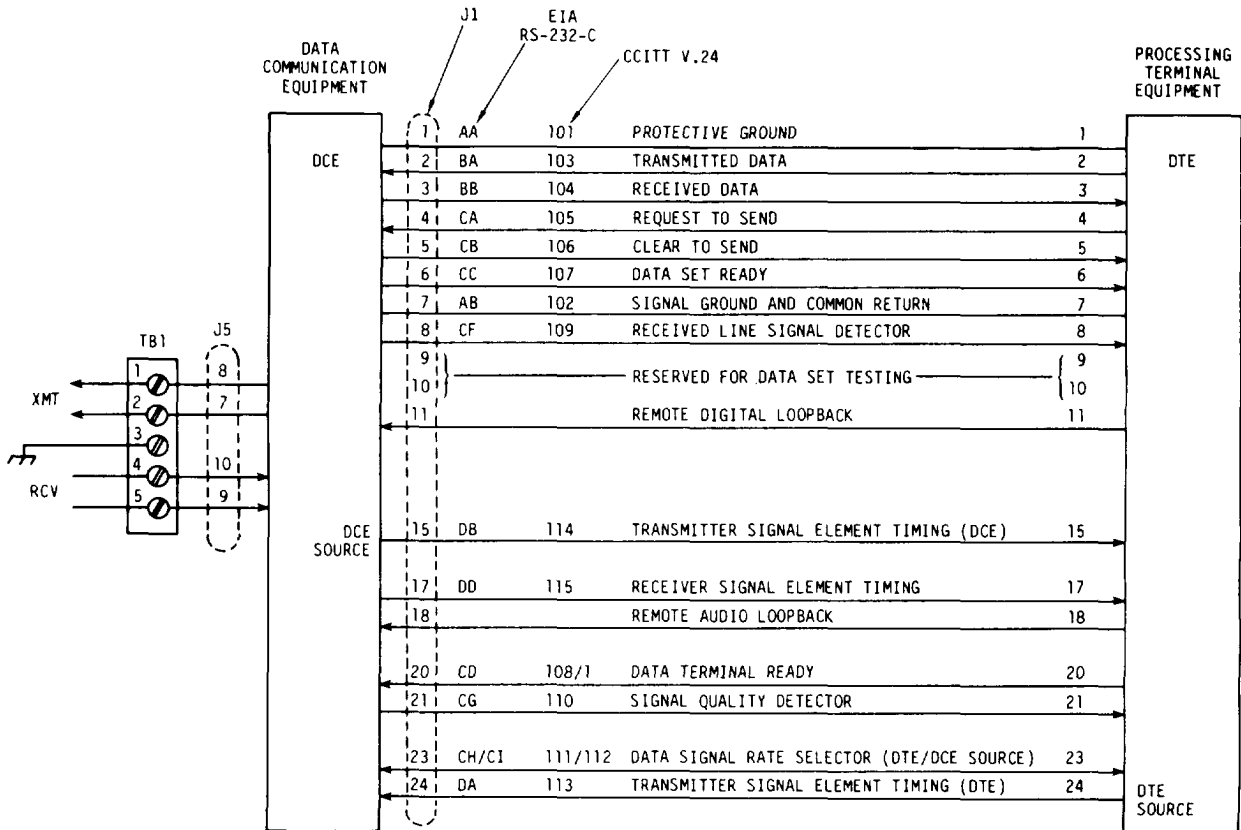

Figure 1-12. Interface Signals

Table 1-3. Interface Signal Descriptions

EIA RS-232C	CCITT V. 24	J1	Signal Name	Description
AA	101	1	Protective Ground or Earth	Chassis ground. Isolated from signal ground or common return (AB, pin 7).
AB	102	7	Signal Ground or Common Return	Common signal and dc power ground. Isolated from Protective Ground (AA, pin 1).
BA	103	2	Transmitted Data	Serial digital data from a data terminal or other digital data source accompanied by DB. If accompanied by an external data rate clock (DA), data transitions must occur on positive going transitions of the external transmit input clock.
BB	104	3	Received Data	Serial digital data at the output of the modem receiver. The data is accompanied by an internal data rate clock (DD) whose positive going transitions occur on the data transitions.
CA	105	4	Request to Send	A positive level to the modem when data transmission is desired.
CB	106	5	Clear to Send	A positive level from the modem with a selectable delay, after receipt of Request to Send (CA) and when the modem is ready to transmit. Clear to Send is low during training or when Request to Send is low.
CC	107	6	Data Set Ready	A positive level from the modem when power is on and not in the Test mode.
CF	109	8	Received Line Signal Detector	A positive level from the modem except when a loss of the received input signal is detected (carrier detect).
--	---	11	Remote Digital Loopback	A positive level or pulse will cause a digital loopback at a remote modem in modems with a Remote Loopback option.

Table 1-3. Interface Signal Descriptions -- Continued

EIA RS-232C	CCITT V. 24	J1	Signal Name	Description
--	--	18	Remote Audio Loopback	A positive pulse will cause an audio loopback at a remote modem.
CG	<b>110</b>	21	Signal Quality Detector	A positive level from the modem in response to a jumper-selectable EQM Bad or ERR Bad signal.
CH/CI	111/ 112	<b>23</b>	Data Signal Rate Selector	To supply a data rate indication to the terminal, position the CH/CI jumper, located on the A3 board, to the CI position. J1-23 will be negative to indicate that 4800 bps or 7200 bps operating speed has been selected manually at the modem. A positive level will indicate that 9600 bps has been selected. For external data rate control, position the CH/CI jumpers on the A3 board to the CH position. The external source will control the rate of the modem. A negative level will switch the modem to the lower operating speed, and a positive dc input will select the higher operating speed.
DA	113	24	Transmitter Signal Element Timing	A serial data rate clock input from the data source. Positive clock transitions correspond to data transitions.
DB	114	15	Transmitter Signal Element Timing	A transmit data clock output for use by an external data source. Positive clock transitions correspond to data transitions.
DD	115	17	Receiver Signal Element Timing	A receiver data rate clock output for use by the external data sink. Positive clock transitions correspond to data transitions.

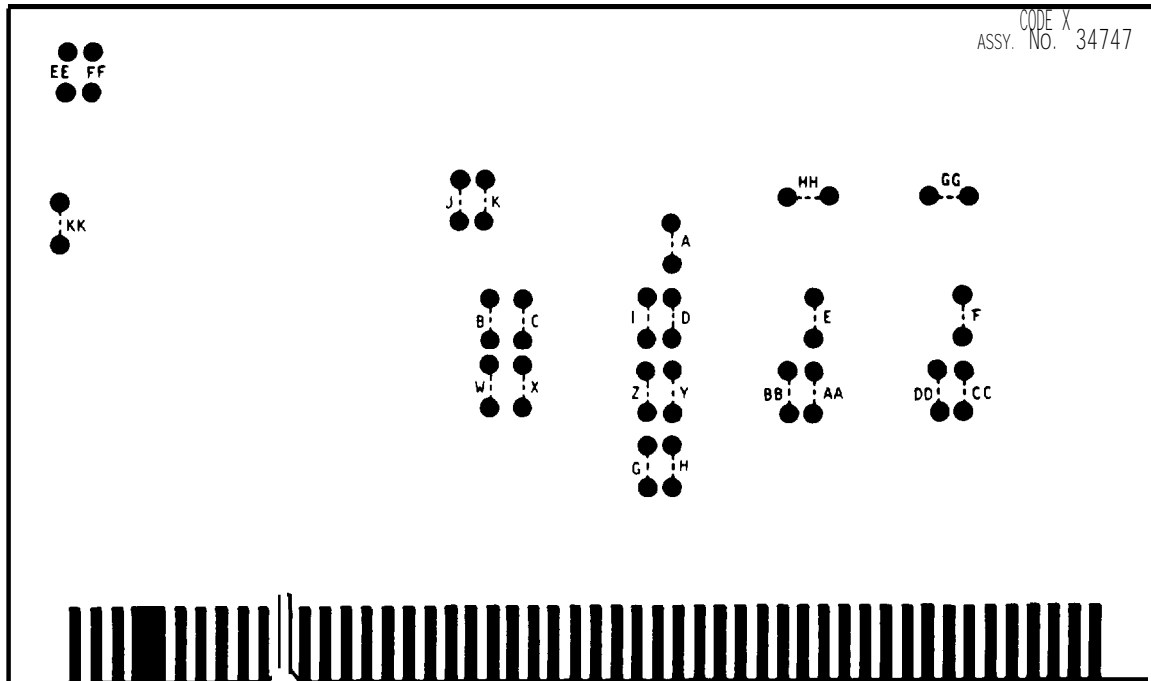

Figure 1-13. 1/O Board (A9) Jumpers (Backside)

Table 1-4. 1/O Board (A9) Jumpers

Jumper	Normal Configuration	Description
A	OUT	Allows RLB Audio Loopback Command to be sent by EIA signal on J1-18.
B	OUT	Allows RLB dc Loopback Command to be sent by EIA signal on J1-11.
NOTE		
Multiplex functions are options for this modem.		
C	IN	Allows channel 1 multiplexer port remote loopback by control of EIA signal on J1-11 when multiplexer is present and has control signaling option.
D	IN	Same as jumper C, except for channel 2 of multiplexer.
E	IN	Same as jumper C, except for channel 3 of multiplexer.
F	IN	Same as jumper C, except for channel 4 of multiplexer.
W, X	OUT	With jumpers in, puts (+) unregulated voltage on J1-9 and (-) unregulated voltage on J1-10.
Y, Z	OUT	Same as W, X except on J2.
AA, BB	OUT	Same as W, X except on J3.

Table 1-4. Domestic 1/0 Board (A9) Jumpers -- Continued

Jumper	Normal Configuration	Description
CC, DD	OUT	Same as W, X except on J4.
EE & FF	OUT	Normal configuration when the transmit pre-emphasis capability is not used. If use of pre-emphasis is desired, remove jumper from EE and add to FF.
GG	IN	Local Audio Loopback may be controlled by an EIA signal on J1-19.
HH	IN	Local dc Loopback may be controlled by an EIA signal on J1-13.
KK	OUT	With jumper installed, the transmit audio level is reduced by 1 dB.
G, H, I, J, K	OUT	These jumpers are not used in this model.

f. Rate/Mode Display Board. One jumper is located on the rate/mode board (fig 1-14) and is used to blank out the rate/mode display so no indications are visible at the modem front panel. The V.29 modem is normally shipped with the blanking jumper removed so the indications are visible.

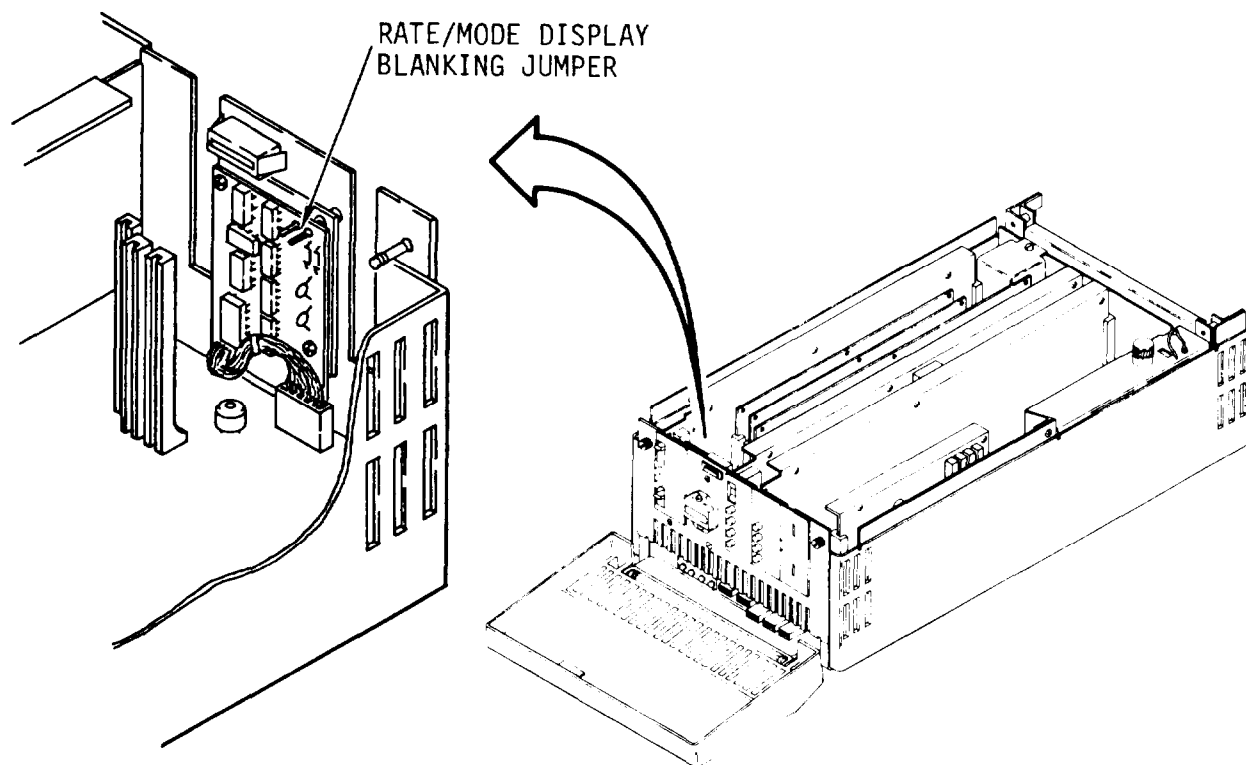

Figure 1-14. Rate/Mode Display Blanking Jumper



## CHAPTER 2 TECHNICAL PRINCIPLES OF OPERATION

This chapter explains how the V.29 modem works, and how it interfaces with transmission lines to send and receive data.

### 2-2. OPERATING PRINCIPLES

The V.29 modem normally operates unattended except for normal monitoring of indicator lamps. Each local and remote modem is automatically synchronized if output rate quality degrades during operation. The input and output data rate is normally 9600 bps. It is possible for the unit to switch down automatically to a lower rate if degradation does occur. Start up is accomplished by the operator using controls on the front panel.

### 2-3. CONTROLS AND INDICATORS

All operating controls and indicators are accessible from the front of the modem (fig. 2-1). Access to mode and rate controls, status indicators, and diagnostic test switches is obtained by lowering the front panel.

a. Mother Board Controls. The mother board controls and indicators are located at the bottom of the front panel and are shown and described in figure 2-2.

b. Front Panel Controls and Indicators. The controls and indicators for the different boards are found on the edges of the boards and protrude through slotted locations on the front panel (fig. 2-3).

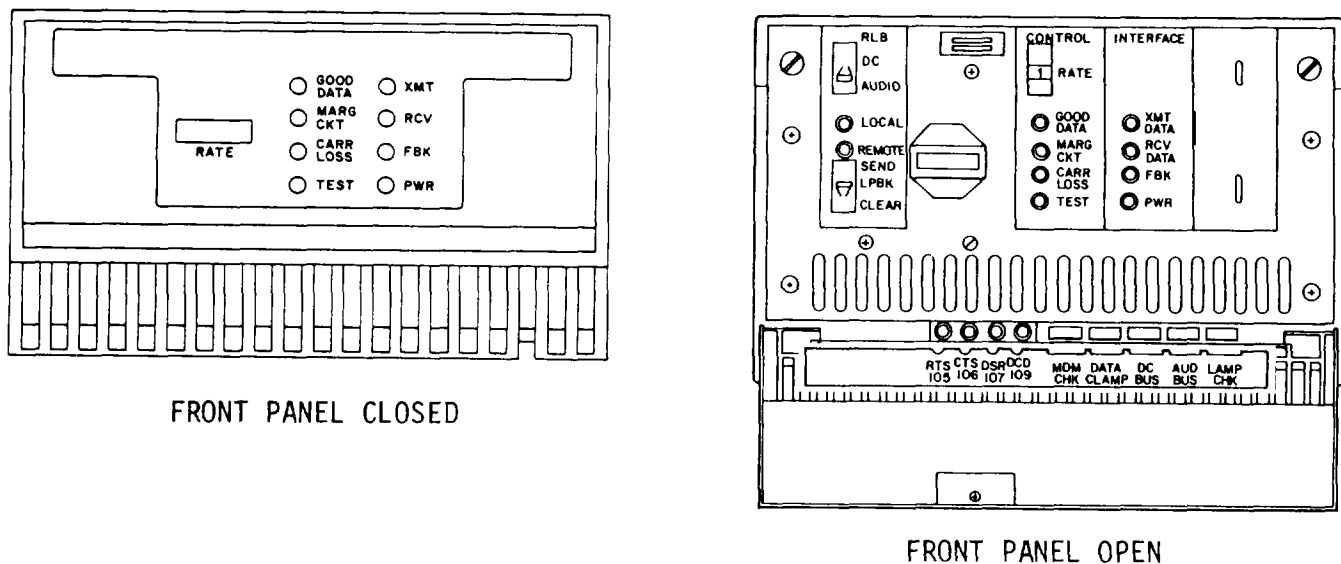
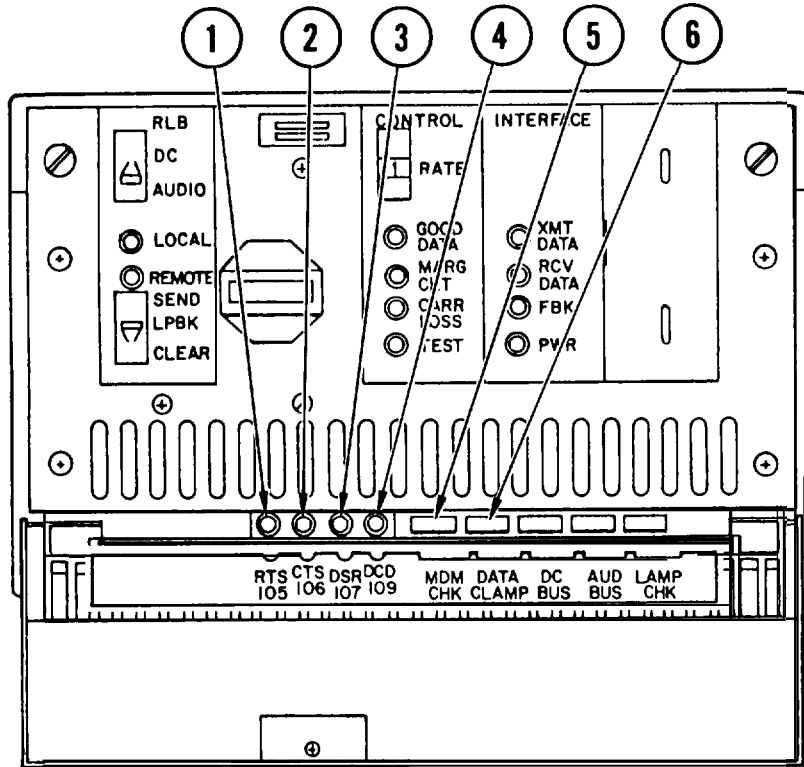
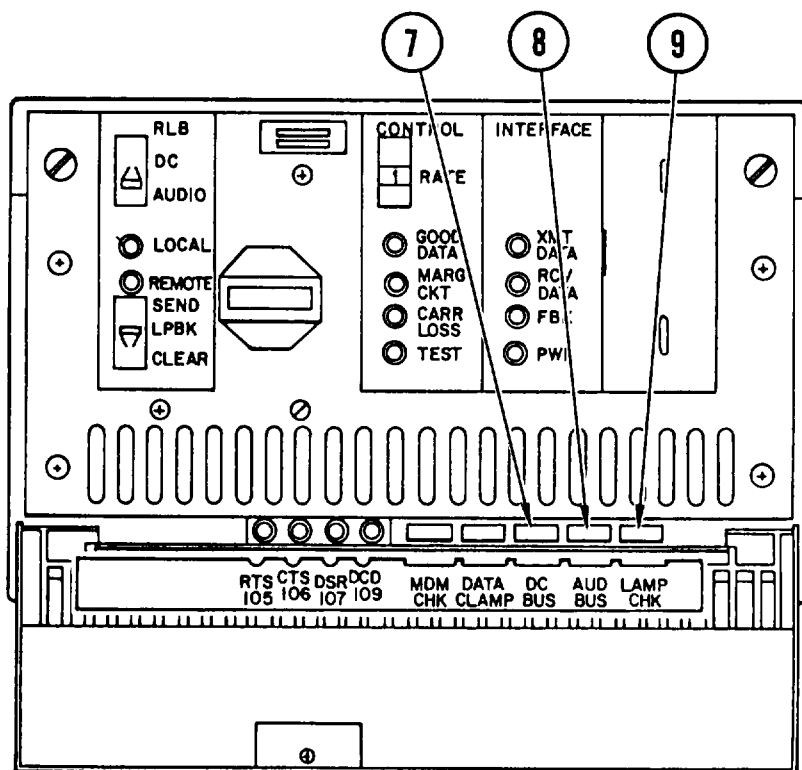

Figure 2-1. Front Panel



- |  |  |
|--|--|
| <p>① RTS (Request to Send) indicator</p> <p>② CTS (Clear to Send) indicator</p> <p>③ DSR (Data Set Ready) indicator</p> <p>④ DCD (Carrier Detect) indicator</p> <p>⑤ MDM CHK switch</p> <p>⑥ DATA CLAMP switch</p> | <p>Lights when data terminal provides a Request to Transmit data signal to modem transmitter.</p> <p>Lights when modem transmitter is ready to accept data from terminal.</p> <p>Lights when power is on and modem is not in the TEST mode.</p> <p>Lights when received audio signal is detected.</p> <p>When pressed, causes TEST indicator to blink, terminates transmit and receive telephone lines in 600 ohms, and loops modem transmitter output to receiver input through AGC.</p> <p>When pressed, causes TEST indicator to blink, blocks transmit input data, and clamps transmit data input to a Space condition that can be traced through the communications link. The receiving modem displays any error outputs when its DATA CLAMP switch is also activated, allowing bit error rate to be approximately determined without having to use a test pattern generator.</p> |
|--|--|

Figure 2-2. Mother Board Controls and Indicators (1 of 2)



- ⑦ DC BUS switch

When pressed, causes TEST indicator to blink, isolates local data terminal from modem by looping terminal data and clock output back to the input, and connects local modem receiver output data to transmitter data input. The remote modem receives self transmitted data back through the local modem and telephone lines.
- ⑧ AUD BUS switch

When pressed, causes TEST indicator to blink and connects receive telephone line through receiver AGC to transmit output amplifier. Transmit audio signal, which normally feeds the transmit output amplifier, is connected to the receiver input, post-AGC. This allows the local data terminal to receive output data back through the local modem transmitter and receiver, and provides an audio loopback for the remote modem through the local modem transmit output amplifier and receiver AGC circuits. This switch has no effect when the modem is a multipoint master.
- ⑨ LAMP CHK switch

Pressing the momentary-contact LAMP CHK switch should light all the modem indicators. Operation of the LAMP CHK switch does not affect normal data transmission and reception.

Figure 2-2. Mother Board Controls and Indicators (2 of 2)

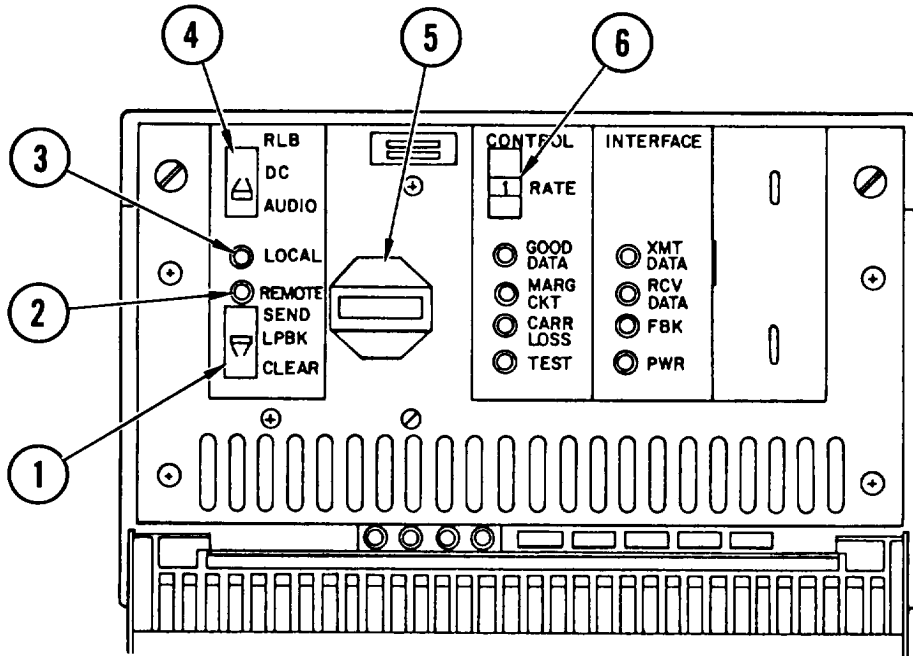

- ① SEND/LPBK/CLEAR (A8 Board)      Momentary toggle switch used to select the SEND command, OFF, or the CLEAR command.
- ② REMOTE indicator (A8 Board)      Light-emitting diode which lights to indicate that a Remote Audio Busback or Remote Dc Busback has been selected.
- ③ LOCAL indicator (A8 Board)      Light-emitting diode which lights to indicate that a remotely requested Dc Loopback or Audio Busback has been performed locally.
- ④ RLB/DC/AUDIO switch (A8 Board)      Toggle switch used to select Remote Dc Busback or Remote Audio Busback.
- @ RATE/Mode indicator      Alphanumeric display of the selected data rate and mode of operation for the modem. The RATE is derived from the output of the frequency counter circuit which monitors transmit data clock pulses for the transmit selected rate. The mode is derived from the control board configuration jumper selection (table I-1).
- ⑥ Data RATE thumbwheel selector (A4 Board)      Thumbwheel switch **used to** select the data transmission rate. Settings are 1 thru 5 (fig. 1-9).

Figure 2-3. Front Panel Controls and Indicators (1 of 2)

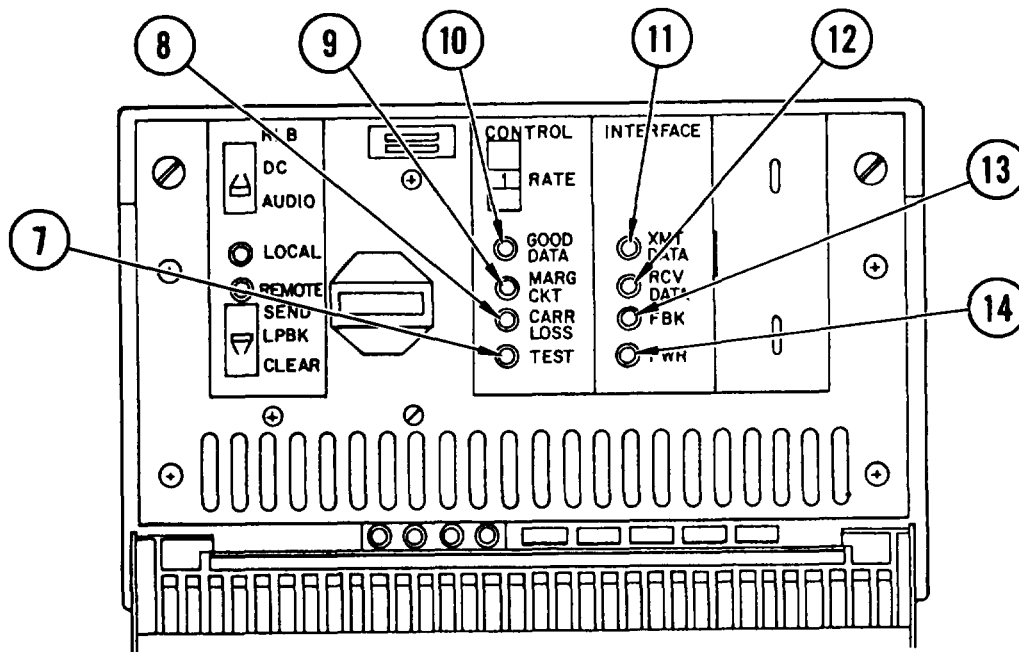

- ⑦ TEST indicator (A4 board)                      Flashes when any test switch is pressed. This indicator is visible through the front panel.
- ⑧ CARR LOSS indicator (A4 board)                      Lights when the carrier signal from the remote modem transmitter is lost.
- ⑨ MARG CKT indicator (A4 Board)                      When the amplitude error rate is below a predetermined threshold, the GOOD DATA indicator is lit. For an error rate greater than the threshold, the GOOD DATA indicator remains lit and MARG CKT also lights. A bit error rate less than the threshold extinguishes the GOOD DATA indicator, leaving only the MARG CKT lit.
- ⑩ GOOD DATA indicator (A4 Board)                      Lights for a mark at the transmit logic data input, indicating transmit input data activity.
- ⑪ XMT DATA Indicator (A3 board)                      Lights for a mark at the receive logic data output, indicating receive output data activity.
- ⑫ RCV DATA Indicator (A3 board)                      Lights whenever the RATE switch is not in position 1 or CH fallback is enabled.
- ⑬ FBK indicator (A3 board)                      Lights when regulated voltage is present.
- ⑭ PWR indicator (A3 board)

Figure 2-3. Front Panel Controls and Indicators (2 of 2)

## 2-4. FUNCTIONAL DESCRIPTION

In order to transmit data between widely separated terminals, two similar modems are required. The transmitter section of each modem generates and modulates a data carrier signal handled by the link with minimal distortion. The receiver section of each modem demodulates the incoming carrier and prepares the data for use by the other terminal. The following functional description is keyed to the V.29 modem functional block diagram (fig. 2-4).

### 2-5. POWER SUPPLY AND POWER DISTRIBUTION

The power supply generates four dc voltages: +10 V, +7 V, -7 V, and -10 V. The integrated circuits on the equalizer use +7 V and -10 V. The transmitter, and receiver boards use +7 V, +10 V, and -10 V. Analog circuits (op amps) on the interface board use +10 V and -10 V, and the logic circuits on the control board use +7 V and -7 V. Two unregulated voltages are generated: one positive to feed the +10 V and +7 V regulators, and one negative to feed the -10 V and -7 V regulators. The unregulated input filter has a choke input, which provides isolation of the regulators from the ac line.

a. Dc Power Distribution. The two unregulated voltages are routed through the mother board before entering the regulator board. If the regulator board is removed, power is cut in the unit.

b. Unregulated Assembly. The unregulated power supply assembly contains the ac line filter, fuse, power switch, 115/230 V ac switch, chassis ground stud, power transformer, rectifier bridge, and two chokes. The two capacitors which form the rest of the choke input filters are located on the regulator board. The unregulated chassis forms a modular unit which has four electrical interconnects to the motherboard; chassis ground, signal ground, and the two unregulated voltages. These are connected to the motherboard via a box connector.

### 2-6. REGULATORS

The three regulators are located on the power regulator board (fig. 2-5). The +10 V, -7 V, and -10 V regulators are three terminal regulators which have their ground terminal boosted to create higher output voltages than normally given by the regulator. The booster circuits consist of a resistive voltage divider, an op amp, and either an NPN or PNP transistor dependent on the polarity of the +10 or +7 V output voltage. The voltage divider determines the output voltage +10 or +7 V. The three terminal regulators are short circuit proof, thus providing output protection.

### 2-7. TRANSMITTING FUNCTION

Data, commands, and clock information from a local terminal are sent through the interface (A3) and control board (A4). This data is scrambled, and transmitted to the input/output board (A9). From the I/O board the data is transmitted to remote terminal modems.

a. Interface Board (A3). Input data from the computer, request-to-send command and transmit timing signal enter the interface board. These are then sent to the control board. Commands to send and transmit clock signals from the control board (A4) are returned to the computer through the interface board.

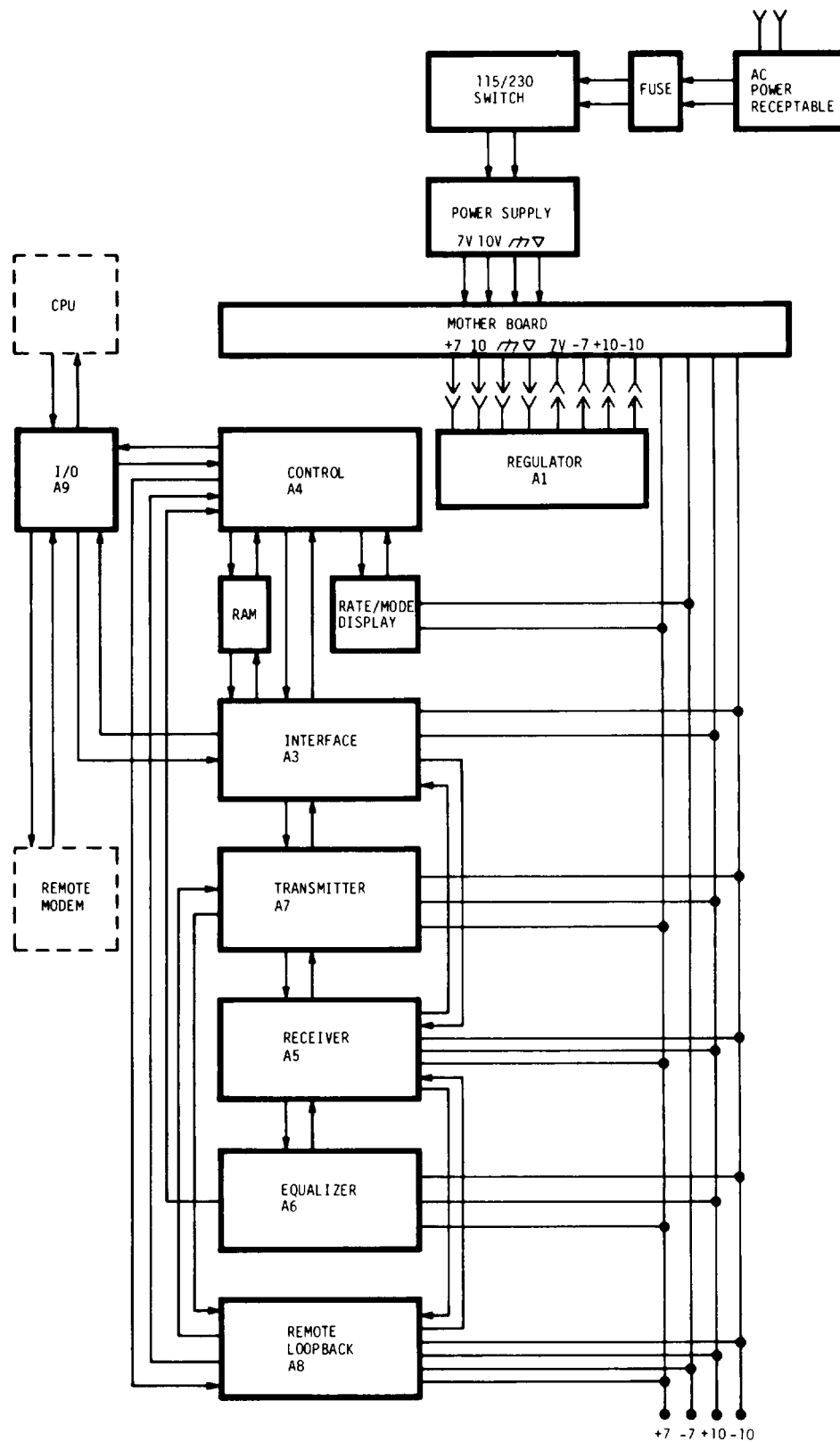

Figure 2-4. V.29 Modem Assembly Functional Block Diagram

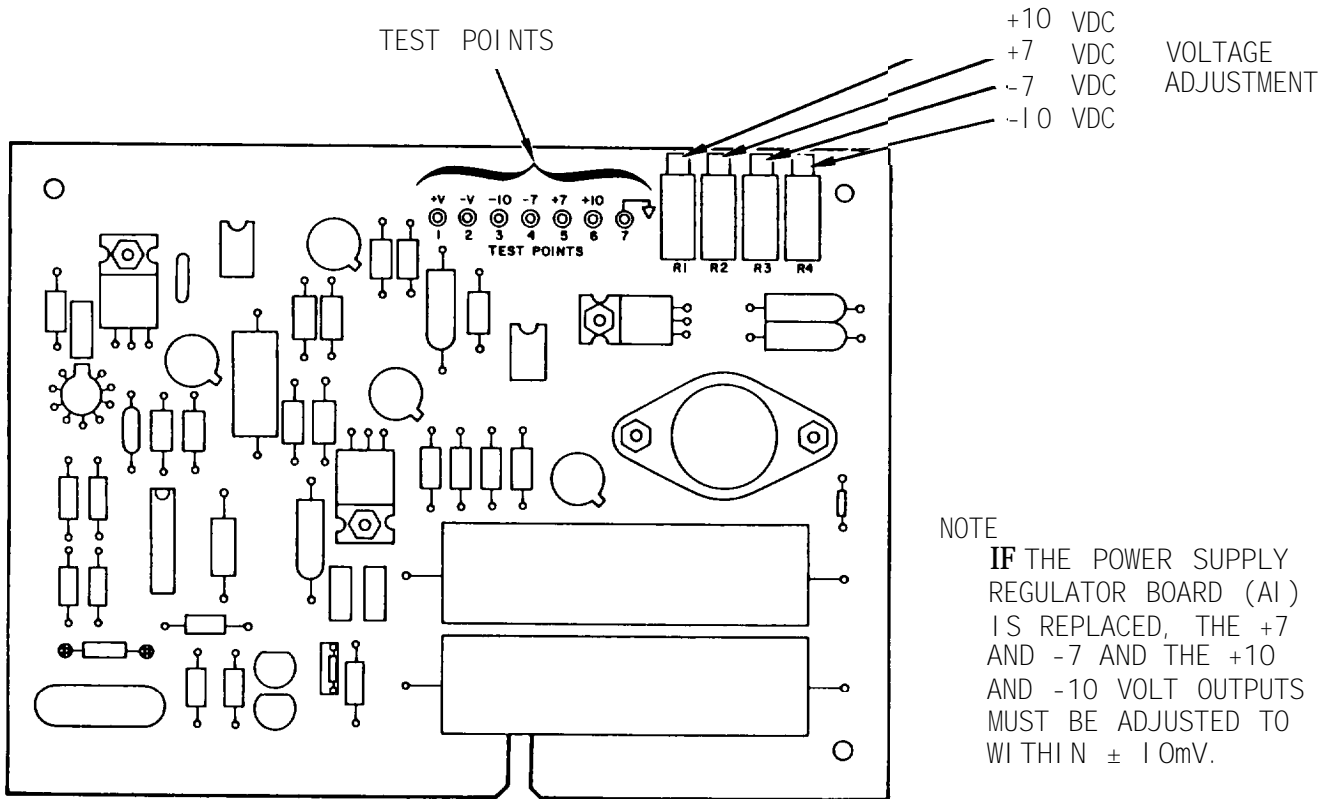

Figure 2-5. Power Supply Regulator Board (A1)

b. Control Board (A4). Data, commands, and signals are received by the control board. Data is handled in or out. This board contains the logic circuitry for the train function (synchronized between transmitter and receiver). It also contains the clock timing selector, rate/mode, and configuration control.

Transmitter Board (A7). Data to be transmitted consists of synchronous (timed) digital information. To make it less subject to losses on its line, the digital signal is coded, scrambled, modulated and digital-to-analog converted. This data is transmitted at either a 1200, 1600, or 2400 baud rate. Data from the transmitter then goes to the I/O board and out on pins 7 and 8 of J5.

2-8. RECEIVING FUNCTION

Data from a transmitting V.29 modem is received by the remote unit receiver board (A5). It is then sent through the equalizer (A6), control (A4), and interface (A3) boards.

a. Receiver Board (A5). Incoming audio signals from the remote modem are received at terminals four and five of TB-1 or terminals nine and ten of J5. This input is AGC amplified, analog-to-digital converted and demodulated. It is then equalized, decoded, descrambled, and sent to the control board. The receiver also recovers the carrier and timing.



b. Control Board (A4). Data from the receiver is logically controlled for loopback and other test purposes. This board also controls the configuration and training mode of the receiver and generates control signals to the terminal. Received data and commands are sent from control board to the interface.

c. Interface Board (A3). Data commands and clock information are sent through the interface board.

## 2-9. UNATTENDED REMOTE LOOPBACK

The remote loopback option allows a central site to initiate audio and dc busback tests of the local and remote modems and telephone lines in the absence of any operator at the remote site. This RLB consists of two tone filters and detector circuits located on the remote loopback board (A8). The switches and indicators for this function are mounted on the front edge of the board. Control of audio and dc busback is full-duplex. Either end of a point-to-point system can control the other modem.

a. Remote Loopback Board Description. Various loopback diagnostics are performed by the RLB. They consist of remote loopback of modem in the dc loopback and remote loopback in audio loopback mode. After test use of the loopback function is complete, simultaneous detection of both tones at the remote modem releases both functions. This also restores the modems to normal data modes.

b. Remote Loopback Board Operation. The remote loopback board has two switches and two status indicators. One switch is a DC/AUDIO control. In AUDIO position the SEND switch commands the AUDIO loopback tone to be sent, and similarly, when in the DC position, the SEND switch commands the DC loopback tone to be sent. The DC/AUDIO also determines which of the two loopbacks the status indicator will monitor. The bottom switch is normally in the LPBK (middle) position. Pressing the switch to the SEND position momentarily causes the applicable loopback tone to be sent, dependent on the top switch. Pressing the bottom switch down to CLEAR position momentarily causes both tones to be sent. This clears the loopback.

## 2-10. MULTIPPOINT CONFIGURATION

A multipoint modem contains a built-in multiplexer which enables two or more separate data streams to be combined for transmission over a single circuit. A multipoint modem is basically a modem designed to achieve fast polling acquisition times on multipoint lines.

Multipoint, or multidrop lines, usually are installed for applications that require interactive terminal access from a number of remote locations into a central computer facility. This type of line may link a number of keyboard-display terminals, or they may be installed to provide remote terminal access to a centralized data base for one particular application. An example would be an inventory control system where terminals are located at many warehouses and are used to report shippings and arrivals so that organization inventories are continuously updated. For this application, each terminal uses a small fraction of the total time available to all terminals connected to the line to complete a transaction, and the terminal is addressable and can recognize messages for which it is a recipient.

When configured as a multipoint, the V.29 modem uses the same training sequence and structure as a modem in fast mode. **If** the master does not train, it can be trained by releasing and depressing the slave DC Bus switch.

#### 2-11. SELF TEST AND FAULT ISOLATION

The test switches and indicators built into the V.29 Modem assembly allow a rapid four-step check of the data terminals, modems, and telephone lines. This procedure can be used both to verify normal system operation and to isolate faulty equipment in the event of failure. The results of each test step immediately verify the operational performance of each unit in the system or provide a positive indication of equipment failure. The modem also has a self-test feature. This feature links the data in and data out circuits sending the receiver output to the transmitter, completing the loop.

## CHAPTER 3 ORGANIZATIONAL MAINTENANCE INSTRUCTIONS

### Section 1. REPAIR PARTS, SPECIAL TOOLS, TMDE AND SUPPORT EQUIPMENT

#### 3-1. COMMON TOOLS AND EQUIPMENT

For authorized common tools and equipment refer to the Modified Table of Organization and Equipment (MTOE) applicable to your unit.

#### 3-2. SPECIAL TOOLS, TMDE, AND SUPPORT EQUIPMENT

Refer to TM 11-7010-205-23P for a complete listing and description of special tools, TMDE and support equipment required by organizational maintenance. Also refer to appendix B for a list of tools pertaining to the modem assembly.

#### 3-3. SPARES AND REPAIR PARTS

Refer to TM 11-7010-205-23P for a complete listing and description of spares and repair parts required for organizational maintenance of this equipment.

### Section II. SERVICE UPON RECEIPT

#### 3-4. UNPACKING

Upon receipt of new equipment, check packing list and instructions for any precautions or specific unpacking procedures.

#### 3-5. CHECKING UNPACKED EQUIPMENT

Inspect the equipment for damage incurred during shipment. **If** the equipment has been damaged, report the damage on SF 364, Discrepancy in Shipment Report.

Check the equipment against the packing slip to see if the shipment is complete. Report all discrepancies in accordance with the instructions of TM 38-750.

Check the equipment to ensure that required Modification Work Orders have been applied in accordance with DA PAM 310-1.

### Section III. PREVENTIVE MAINTENANCE CHECKS AND SERVICES

#### 3-6. GENERAL

Organizational maintenance PMCS is the required inspection and care of the equipment necessary to keep it in good operating condition. Routine checks like equipment inventory, cleaning, dusting, washing, checking for frayed cables, storing items not in use, covering unused receptacles and checking for loose nuts and bolts are not listed in your PMCS. They are things you should do anytime you see they must be done. **If** you find a routine check like one of these listed in your PMCS, it was listed because operators reported problems with this item.

#### 3-7. PMCS PROCEDURES

PMCS procedures are done at fixed intervals for the following purposes:

- Make sure that the equipment is operable
- Prevent equipment problems in future operation
- Identify and resolve minor problems in the equipment before they become major problems
- Scheduled cleaning of the equipment

#### 3-8. ITEM NUMBER COLUMN

The checks/services in the PMCS table are numbered in order of performance. Use this ITEM number when filling out DA Form 2404 (Equipment Inspection and Maintenance Worksheet).

#### 3-9. ITEM TO BE INSPECTED COLUMN

The items listed in this column are based on the major components of the equipment and use common names of these components.

#### 3-10. PROCEDURE COLUMN

This column gives the check or service procedure which you must perform on the item.

#### 3-11. EQUIPMENT WILL BE REPORTED NOT READY/AVAILABLE IF COLUMN

This column tells you under what conditions the equipment will be unable to perform its primary mission. When you notice this condition during PMCS you must report it on the proper form and tell your supervisor.

Table 3-1. Monthly Organizational Preventive Maintenance Checks and Services

Item No.	Item To Be Inspected	Procedures	Equipment Will Be Reported Not Ready/ Available If:
1	V. 29 Modem	Run self test.	Self test fails.

3-12. RUN SELF TEST

NOTE

This procedure tests:

- Lamp indicators, steps 1-3
- Data in/data out, steps 4-6
- Data in/data out transmitter-receiver, steps 8-9

Data in/data out transmitter-receiver, output amplifier-input AGC, steps 11-12

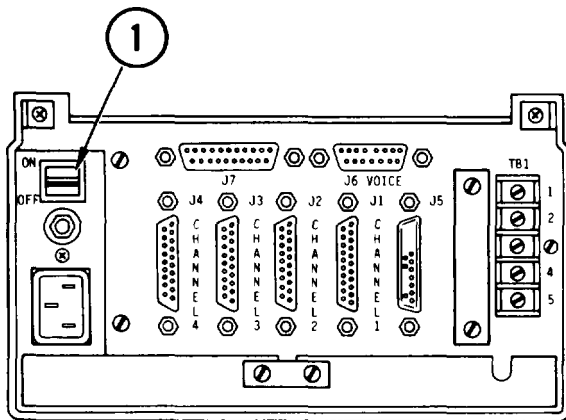

1. Apply power by pressing power switch to ON.

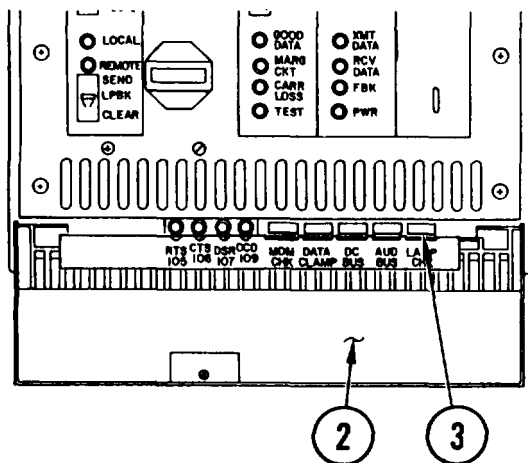

2. Lower front panel cover.
3. Press and hold LAMP CHK. Observe all indicators. If any fail to light, maintenance is required.

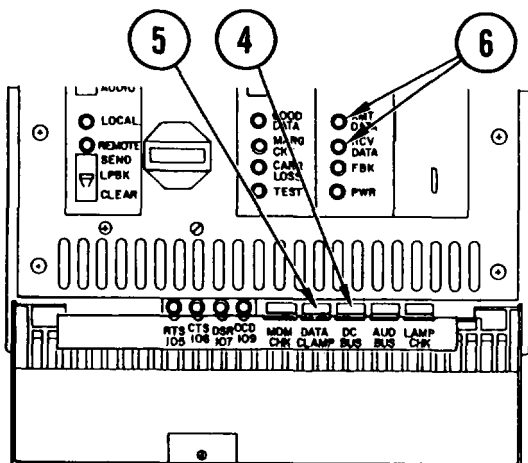

4. Press DC BUS switch until it remains depressed. This activates the loopback circuit.
5. Press DATA CLAMP so it remains in the depressed position.
6. Observe XMT DATA and RCV DATA indicators. XMT DATA indicator should be OFF, and RCV DATA indicator should be ON.
- If condition is not met, test fails and maintenance is required
7. Press DATA CLAMP off and DC BUS off.

3-12. RUN SELF TEST (CONT)

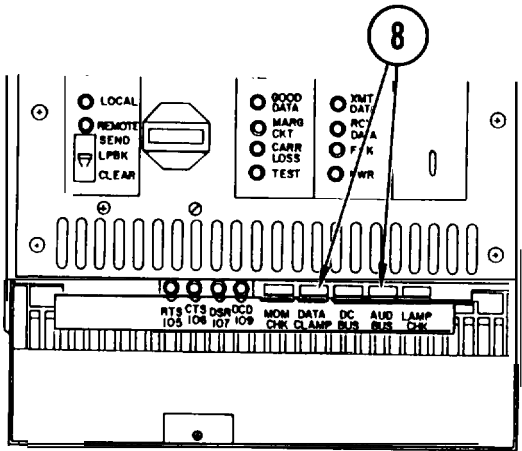

8. Press AUD BUS, then DATA CLAMP so both remain depressed.
9. Observe CONTROL indicators. They should read as follows:

GOOD DATA on  
 TEST on (blinking)  
 MARG CKT off  
 CARR LOSS off  
 XMT DATA off  
 RCV DATA off

o If any indicators read differently, test fails and maintenance is required

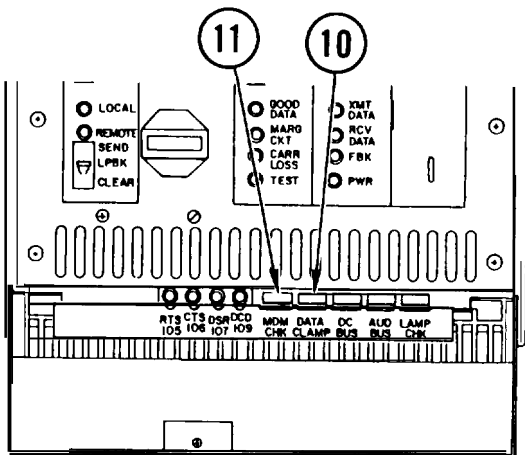

10. Press DATA CLAMP and AUD BUS to off.
11. Press MDM CHK and then DATA CLAMP until both remain depressed.
12. Observe control indicators. They should read as follows:

TEST on (blinking)  
 GOOD DATA on  
 CARR LOSS off  
 XMT DATA off  
 RCV DATA off

● If any indicators show a difference in indication, maintenance is required

13. Press MDM CHK and DATA CLAMP to OFF.
14. Close front panel cover.

## CHAPTER 4 DIRECT SUPPORT MAINTENANCE INSTRUCTIONS

### Index of Maintenance Procedures

Paragraph No.	Title	Page No.
4-11	Access/Close Up V. 29 Modem	4-9
4-12	Remove/Replace Power Supply Assembly	4-11
4-13	Check/Adjust Power Supply Voltage	4-12
4-14	Remove/Replace Fuse	4-14
4-15	Remove/Replace Rate/Mode Display Board	4-15
4-16	Remove/Replace Input/Output Board	4-17
4-17	Remove/Replace Mother Board	4-18
4-18	Remove/Replace Circuit Boards A1 thru A8	4-19

### Section 1. REPAIR PARTS, SPECIAL TOOLS, TMDE AND SUPPORT EQUIPMENT

#### 4-1. COMMON TOOLS AND EQUIPMENT

For authorized common tools and equipment, refer to the Modified Table of Organization and Equipment (MTOE) applicable to your modem.

#### 4-2. SPECIAL TOOLS, TMDE, AND SUPPORT EQUIPMENT

Refer to TM 11-7010-205-23P for a complete listing and description of special tools, TMDE and support equipment required by direct support maintenance. Also refer to appendix B for a list of tools pertaining to the modem.

#### 4-3. SPARES AND REPAIR PARTS

Refer to TM 11-7010-205-23P for a complete listing and description of spares and repair parts required for direct support maintenance of this equipment.

### Section II. TROUBLESHOOTING

#### 4-4. GENERAL

Failure of this equipment is usually determined by a system level diagnostic program. See your system manual for instructions. Upon determination of equipment failure, the modem assembly is removed from the system for fault isolation.

The most effective way to find a fault in this equipment is to follow a routine which guides you through the five phases of troubleshooting (fig. 4-1). By following this routine you assure accurate use of fault isolation and fix procedures. You will also improve your troubleshooting skills.

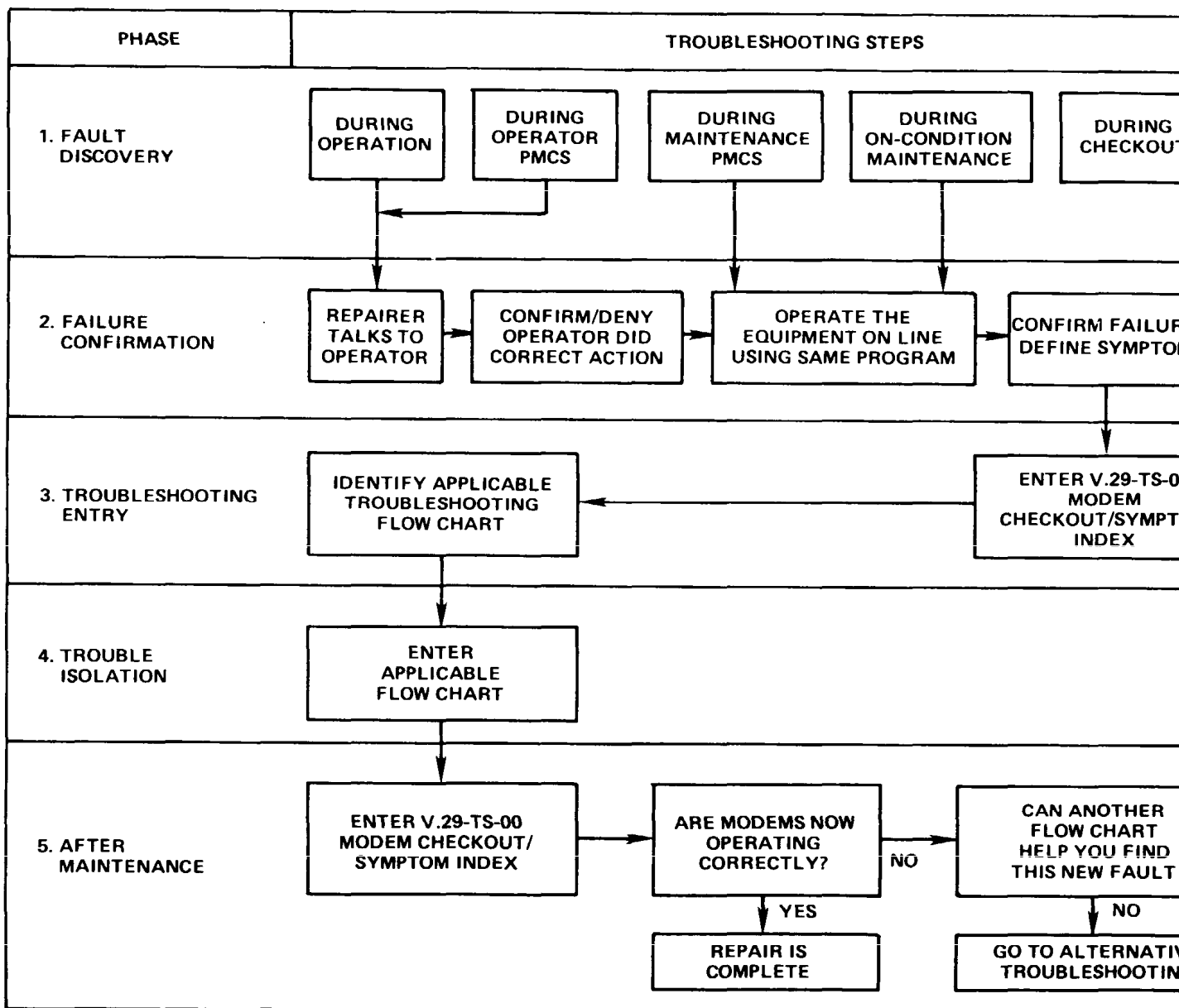

Figure 4-1. Troubleshooting Phases



#### 4-5. TROUBLESHOOTING PHASES

Each of the five phases in this routine is designed to accomplish a specific goal.

- a. Fault Discovery. Usually, the operators or supervisor will notice faulty performance first. They must report the fault on the proper form so you will have the facts you need for the next phase.
- b. Failure Confirmation. Based on the facts provided, you must confirm the failure and define the symptom. The symptom is the first clue you will use in the troubleshooting process.
- c. Troubleshooting Entry. Using the symptom defined during phase two, find the troubleshooting flow chart which will help you isolate the fault in the equipment. The checkout and symptom index chart (chart-00) will help you do this.
- d. Trouble Isolation. Follow the step-by-step procedures in the flow chart to isolate and correct the cause of the equipment failure.
- e. After Maintenance. When you have made the fix recommended in the troubleshooting procedure, you must check your work. Go back to the chart titled Modem Checkout/Symptom Index. It tells you how to test your repair and make sure the equipment now works as it should.

#### 4-6. ALTERNATIVE TROUBLESHOOTING TECHNIQUES









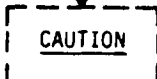
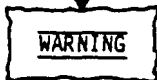

When a failure causes a symptom which is not covered in the symptom index or not corrected by the troubleshooting procedure in the flow chart, you must try alternative techniques.

- a. Understand Principles of Operation. Sometimes the symptom may have no specific procedure given to troubleshoot it. When this happens, remember that the equipment always operates the same way. By comparing the faulty operation with expected *or* normal operation you may find the cause of the failure and be able to fix it.
- b. Check the Circuits. All electronic equipment uses circuits to route power through the components. Any break in continuity will cause some type of failure. By running continuity checks on suspect circuits you may find the cause of the failure. Use the foldout schematic diagram at the rear of this manual to check the circuits in this equipment.
- c. Check Past Maintenance Records. **If** the unusual failure occurred before, it should appear in the maintenance records for the equipment. The records should also tell you how the failure was corrected. Use the same fix this time.
- d. Trial and Error Repair. Usually trial and error repairs should be avoided. They are costly and can induce additional symptoms. However, when your experience with the equipment leads you to suspect a definite cause, you should try the repair as a last resort before shipping the equipment to depot for maintenance.

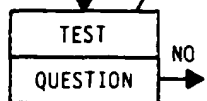
#### 4-7. TROUBLESHOOTING PROCEDURES

The troubleshooting procedures are arranged as flow charts. The charts consist of background information, specific instructions and decision points. Symbols (table 4-1) are used to organize the charts and guide you through a step-by-step trouble isolation procedure for each known failure symptom.

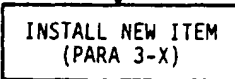
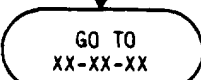
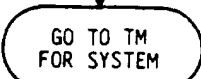
Table 4-1. Flow Chart Symbols

SYMBOL	MEANING
	<p>This is a STARTING POINT Symbol. This is where you enter a troubleshooting flow chart.</p>
	<p>This is a NOTE symbol. It contains information you need to do your work, but which is not a procedural step.</p>
	<p>This is a CAUTION symbol. It alerts you to the possible danger of breaking equipment in the steps that follow.</p>
	<p>This is a WARNING symbol. It alerts you to possible danger in the steps that follow.</p>
	<p>This is an INFORMATION symbol. It contains information that helps you make a test or understand the troubleshooting process.</p>
	<p>This is a TEST/DECISION SYMBOL. It contains a test you must do and a question you must answer. If the results of a test tell you the answer is YES, you will follow the YES arrow to the next symbol. If your answer is NO, you will follow the NO arrow.</p>
	<p>These are CONNECTING POINT symbols. They are used in pairs. If the arrow points to the circle, it is the point where you leave a branch of the flow chart. If the arrow points away from the circle, it is the point where you go back into the flow chart. For example, you would go from  on one page to  on the next page.</p>
	<p>This is a CORRECTIVE ACTION symbol. It tells you what to do to correct the problem. It will also refer you to the paragraph that contains the needed repair or adjustment procedure.</p>
	<p>This is a GO TO symbol. It tells you to go to another flow chart. The X's in the symbol at the left stand for a chart code.</p>
	<p>Other forms for GO TO symbol: This symbol tells you to go to the system Technical Manual for further troubleshooting, such as running a T&amp;V program.</p>
	<p>This symbol tells you to go back to the START point of the same flow chart.</p>

V.29-TS-00	MODEM CHECKOUT/SYMPTOM INDEX
------------	------------------------------

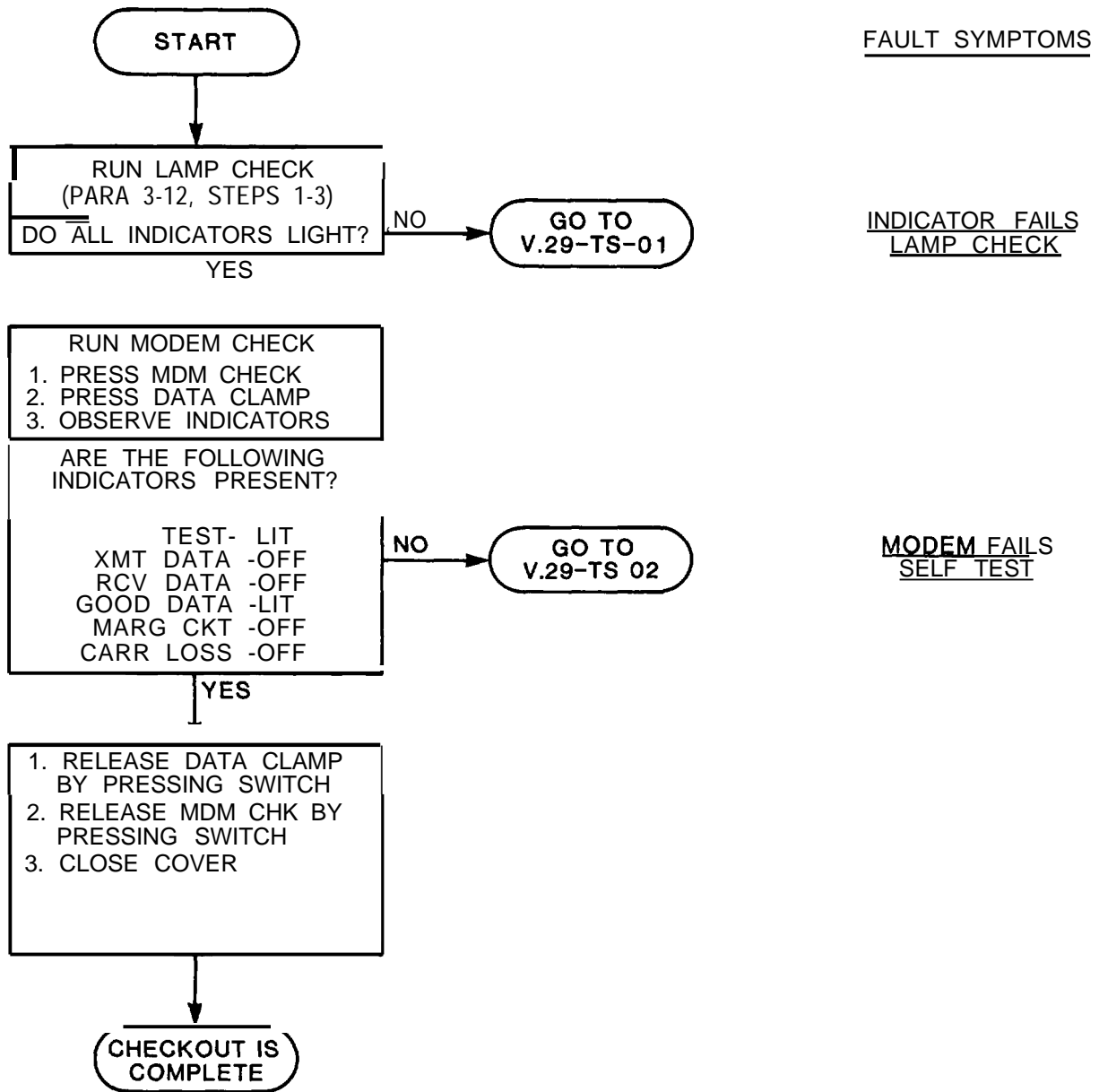

V.29-TS-01 | INDICATOR FAILS LAMP CHECK

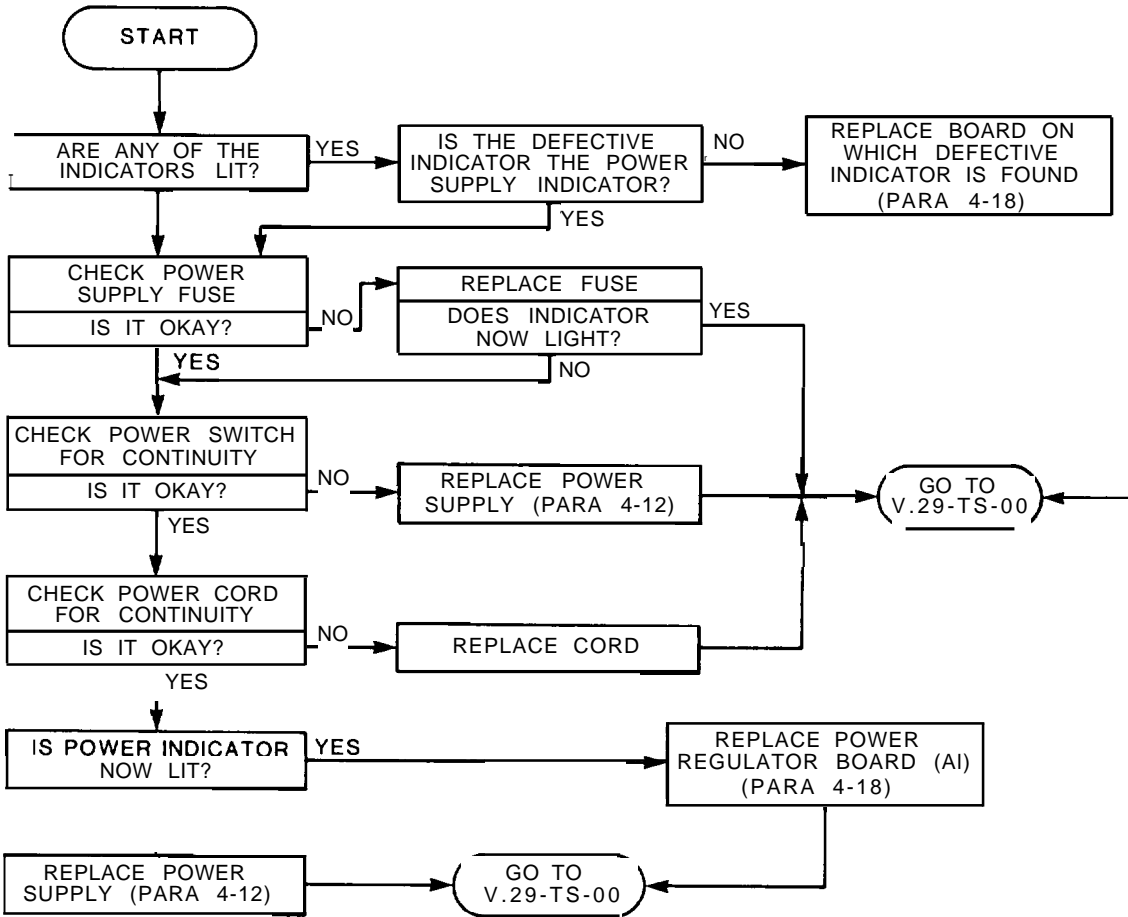

V.29-TS-02 | MODEM FAILS SELF TEST | 1 OF 2

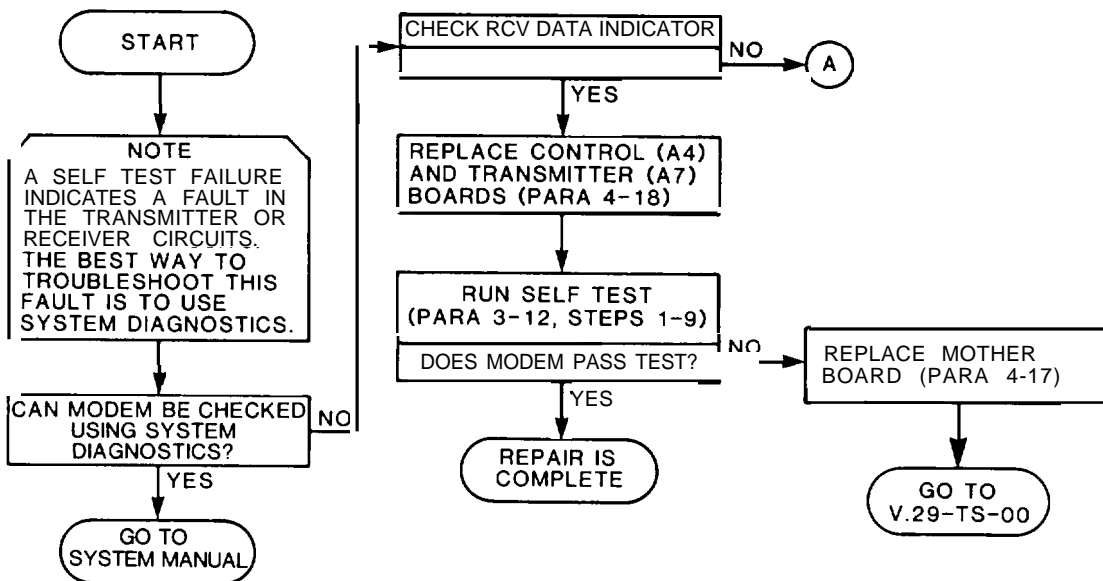

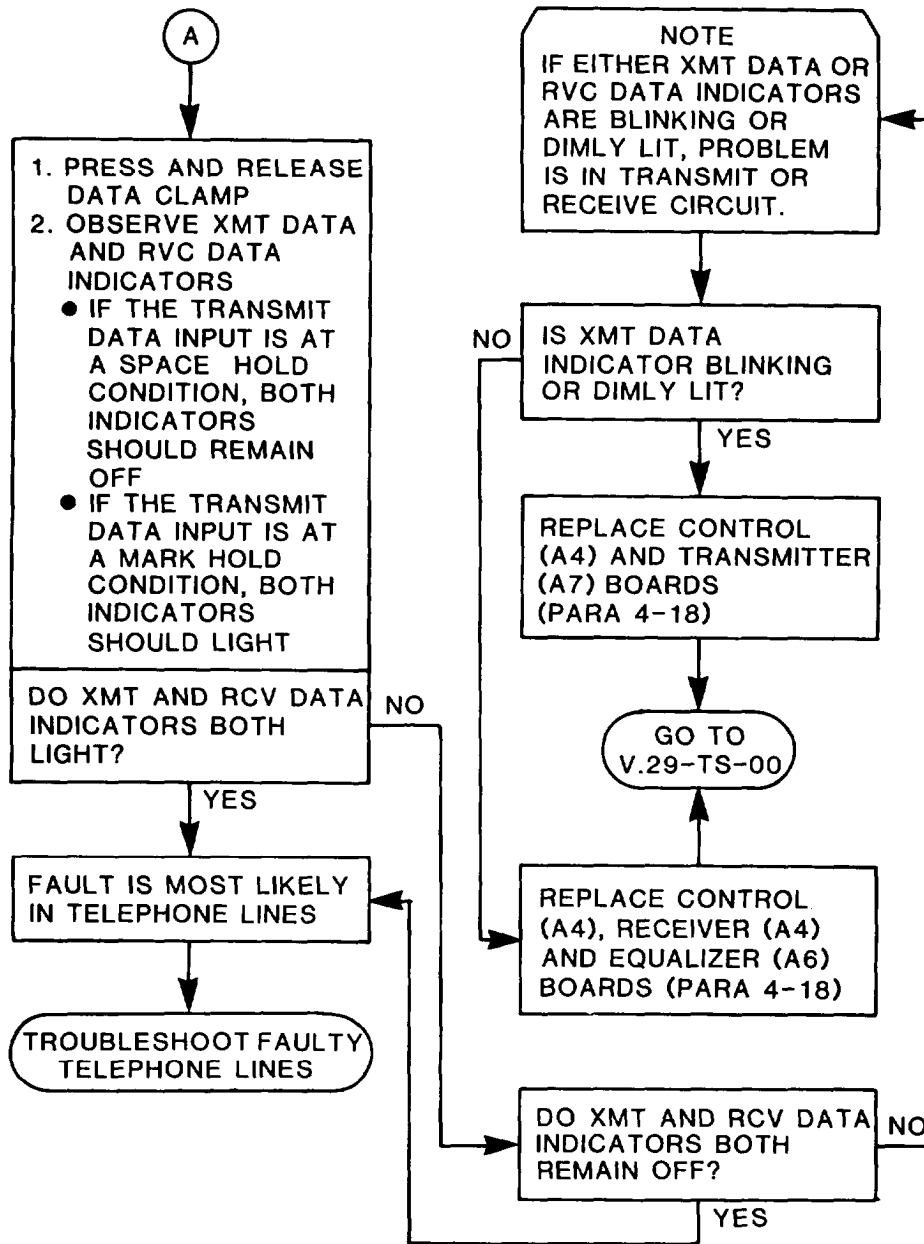

## Section III. MAINTENANCE PROCEDURES

### 4-8. GENERAL

The individual maintenance procedures in this section contain the corrective actions required to fix a failure which was isolated during troubleshooting.

### 4-9. EQUIPMENT HANDLING PRECAUTIONS

Modem boards are sensitive to dirt, smoke, static and humidity. Follow the rules below to avoid damage to the equipment.

- a. Make sure hands, hair, clothing, and shoes are clean before working on the modem assembly.
- b. Do not touch board connector terminals with any tool, bare hands, or a dirty cloth. Tools will damage the fragile connector. Dirt or body sweat will cause corrosion.
- c. Hold boards by their edges whenever you handle them.
- d. **If** a board is to be transported, place it in its original shipping container with antistatic packing. If unavailable, pack it carefully with clean packing material that will prevent physical damage and will not cause corrosion.
- e. Ground your body to discharge static electricity by touching a metal chassis or cabinet before touching a board. A static discharge from you to a board can destroy integrated circuits on the board. Use a ground wrist strap if available.
- f. Store and ship boards in static free bags.
- g. Store boards in a humidity controlled environment.
- h. Do not smoke in the area where boards are used or stored.
- i. Do not put beverages on or near boards. An accidental spill can cause corrosion and chemical damage.
- j. Never leave boards lying around unprotected.
- k. Do not use masking tape labels.

### 4-10. MAINTENANCE PROCEDURES

Before you start a corrective maintenance procedure, you should gather all the items or help listed in the initial setup box for that procedure. Read the procedure carefully and do only what each step tells you to do. Some steps are followed by a reference. Use the reference any time you are not sure what you must do for that step. Always do the steps in the order they are given unless the procedure requires decision steps. When decision steps are involved, go in the order indicated by the decision.

## 4-11. ACCESS/CLOSE UP V.29 MODEM

## INITIAL SETUP

- Common Tools  
 ● Tool kit

## NOTE

In some installations the V.29 modem is rack mounted. See your system manual for removal instructions.

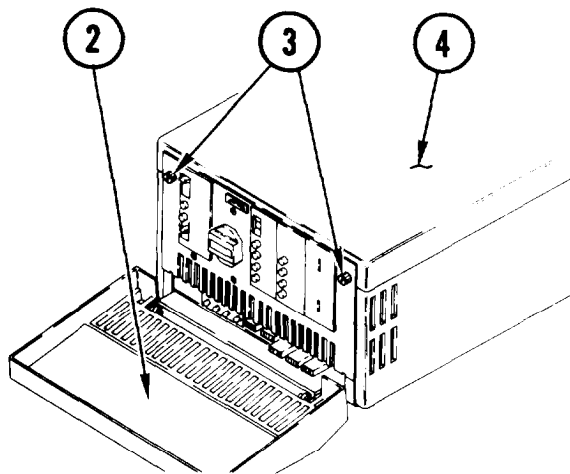
Access

1. Power OFF. Pull ac plug from outlet.
2. Lower front panel cover.
3. Loosen two captive screws located at upper corners of front panel.
4. Slide cover assembly toward rear of modem until top cover disengages from rear channel.
5. Lift off cover.

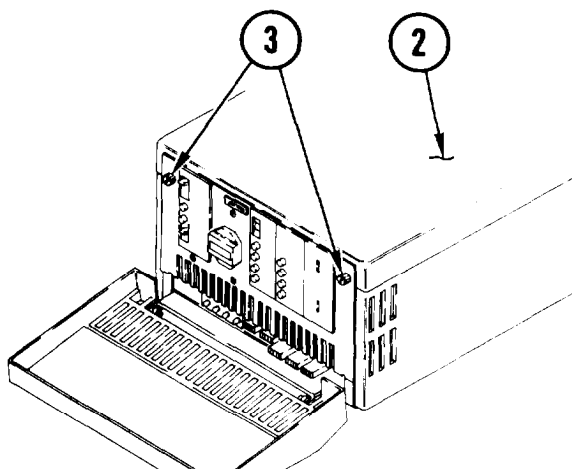
Close Up

1. Place cover in position on rear of modem.
2. Slide cover assembly towards front of modem until rear portion of top cover engages rear channel.
3. Close top cover and secure in position with two captive screws located on front panel.

4-11. ACCESS/CLOSE UP v.29 MODEM (CONT)

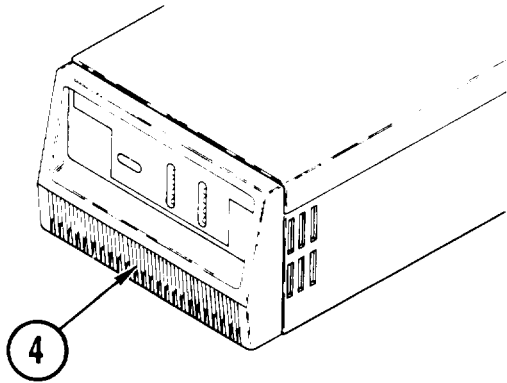

4. Close front panel cover.

NOTE

**In** some installations the V.29 modem is rack mounted. See your system manual for replacement instructions.

5. Plug ac connector into outlet.



## 4-12. REMOVE/REPLACE POWER SUPPLY ASSEMBLY

## INITIAL SETUP

Common Tools  
 ● Tool kit

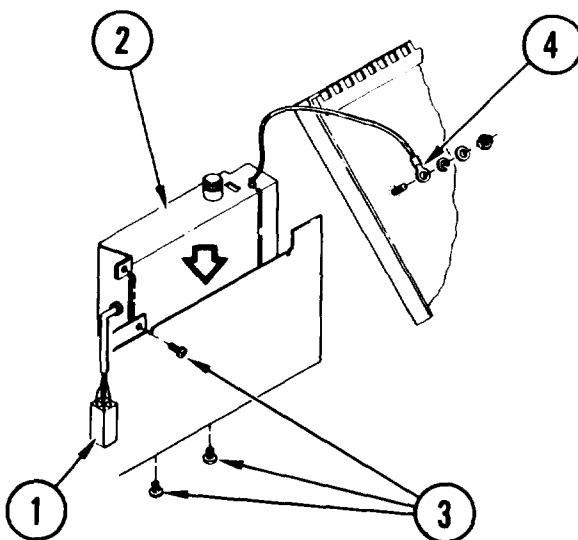
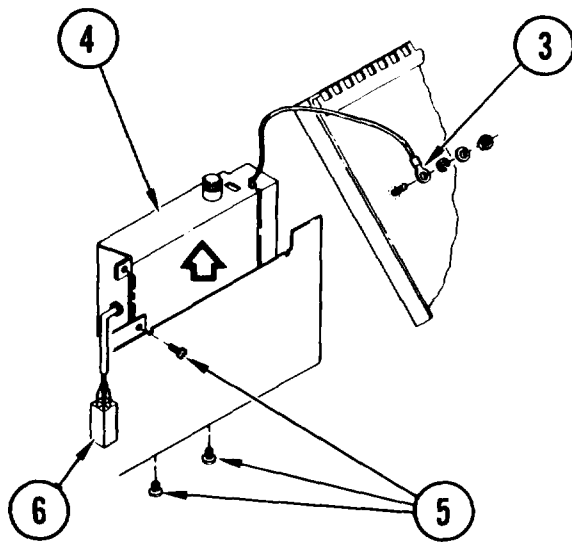
Remove

1. Access modem (para 4-11).
2. Pull ac line plug from rear of modem.
3. Disconnect ground cable from cover by removing nut and washers.
4. Locate power supply assembly.
5. Remove two screws from the bottom of unit and one from the side.

CAUTION

Do not pull on cable to disconnect dc connector. Damage to wire can result.

6. Disconnect dc connector from mother board.
7. Lift power supply forward, up and out of chassis.

Replace

1. Connect dc connector to mother board.
2. Lower power supply into chassis.
3. Install two screws through the bottom and one into the side.
4. Connect ground cable to cover with washers and nut.
5. Push ac line plug into modem.
6. Check power supply voltage (para 4-13, Check steps 2-7).
7. Close up modem (para 4-11).

4-13. CHECK/ADJUST POWER SUPPLY VOLTAGE

INITIAL SETUP

Common Tools  
 ● Tool kit

TMDE  
 ● Multimeter

CAUTION

Before applying power to the modem be aware of all handling precautions for working on boards under power.

NOTE

All boards must be in their respective positions in the modem prior to voltage measurements. Voltages are checked in the top edge of the power regulator board (A1).

Check

1. Access modem (para 4-11).
2. Power ON.
3. Connect multimeter common ground lead to ground pin (TP-7).
4. Connect input lead to voltage test point being tested.

NOTE

+V and -V test points are the voltages (unregulated) from the power supply.

5. Measure the +7 and -7 V dc within  $\pm 10$  mV.
6. Measure the +10 and -10 V dc within  $\pm 10$  mV.
7. If necessary, adjust voltages.

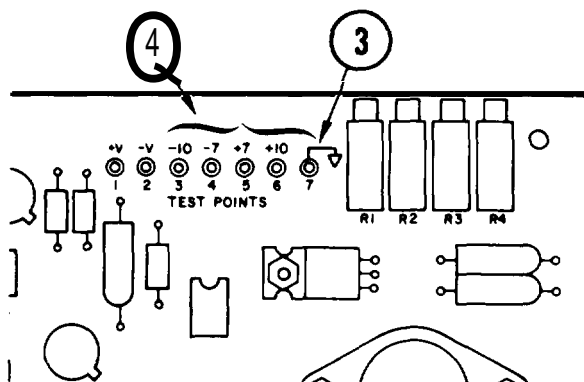

## 4-13. CHECK/ADJUST POWER SUPPLY VOLTAGE (CONT)

Adjust

## NOTE

**If** voltage outputs are not within + 10 mV tolerance they can be adjusted using the potentiometers located on the board near the test points. **If** the power supply regulator board (AI) is changed, the +10, -10, +7, -7 voltage outputs must be adjusted before operation.

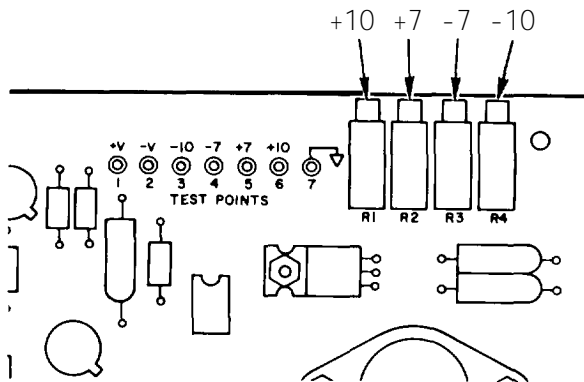

1. Adjust R1 to +10 V dc.
2. Adjust R2 to +7 V dc.
3. Adjust R3 to -7 V dc.
4. Adjust R4 to -10 V dc.
5. Close up modem (para 4-11).

4-14. REMOVE/REPLACE FUSE

INITIAL SETUP

Common Tools

- Tool kit

Materials/Spare Parts

- Fuse (0.25 amp)

Remove

1. Access modem (para 4-11).
2. Push and turn fuse cap as shown and pull fuse out.

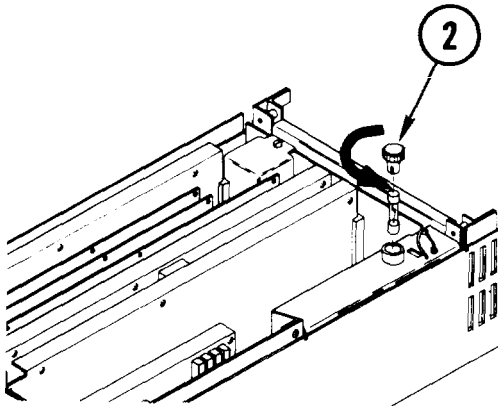

Replace

1. Place 0.25 amp fuse in holder.
2. Install fuse cap and turn as shown to lock in place.
3. Close up modem (para 4-11).

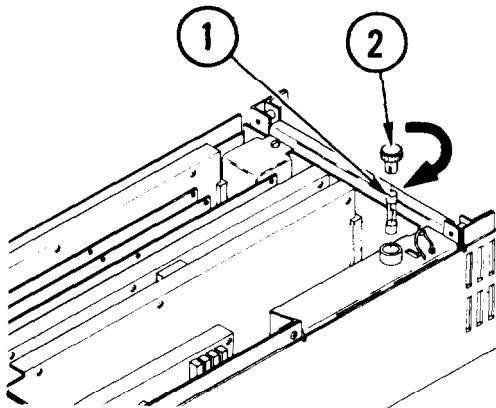

## 4-15. REMOVE/REPLACE RATE/MODE DISPLAY BOARD

## INITIAL SETUP

## Common Tools

- Tool kit

## Materials/Spare Parts

- Antistatic plastic bags

CAUTION

Circuit board devices are sensitive to static electrical charges and require careful handling. Antistatic bags must be used when stowing these circuit boards.

Remove

1. Access modem (para 4-11).
2. Remove circuit boards A1 thru A8 (para 4-18, steps 1-2).

CAUTION

Be careful when removing screws. Spacers could fall into the electronics and damage equipment.

3. Remove four screws securing board to the chassis face plate.

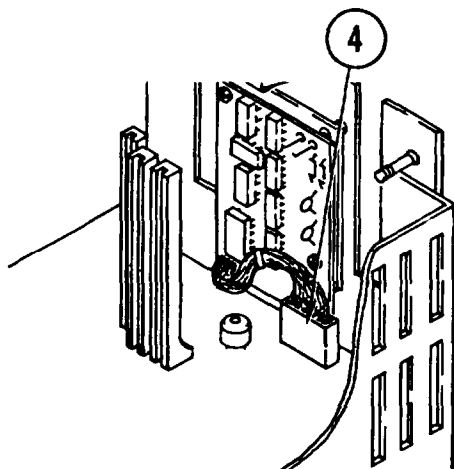
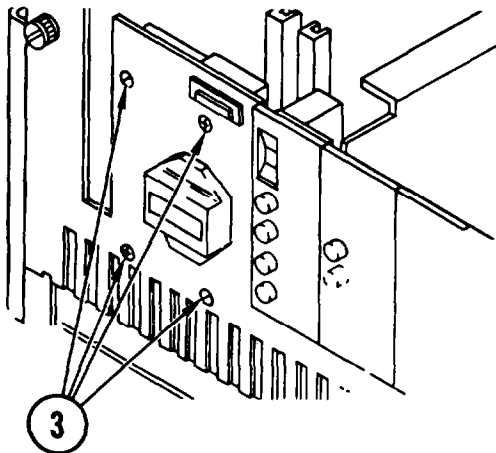

4. Move board aside and unplug connector from the mother board.
5. Lift out board.
6. **If** any spacers have fallen into the modem, remove them.

4-15. REMOVE/REPLACE RATE/MODE DISPLAY BOARD (CONT)

Replace

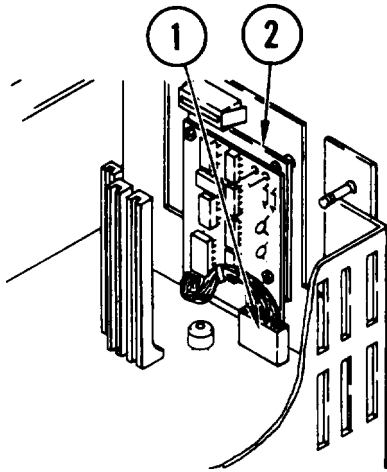

1. Plug connector into mother board.
2. Insert board into position over mounting holes in front panel.

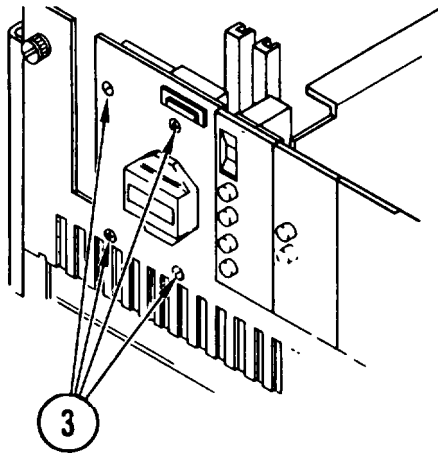

3. Secure board to the modem face plate with four screws and spacers as shown. Make sure each screw passes through a spacer between board and chassis face plate.
4. Replace circuit boards into their respective positions (para 4-18).

4-16. REMOVE/REPLACE INPUT/OUTPUT BOARD

INITIAL SETUP

Common Tools

- Tool kit

Materials/Spare Parts

- Antistatic plastic bags

CAUTION

Circuit board devices are sensitive to static charges and require careful handling. Antistatic bags must be used when stowing these circuit boards.

Remove

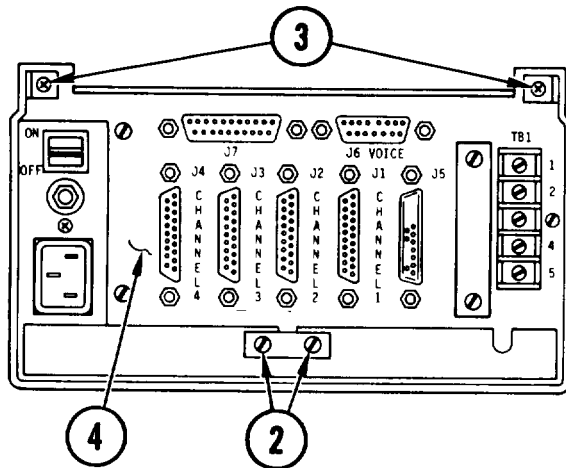

1. Access modem (para 4-11)
2. Loosen two screws.
3. Remove two screws, washers, and lock washers.
4. Unplug board from mother board by gently lifting up on board edge.

Replace

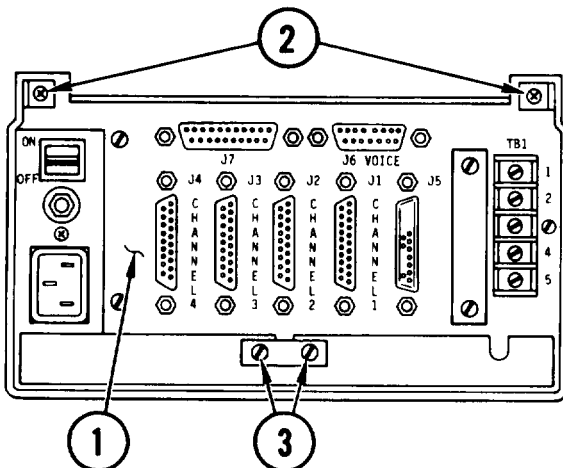

1. Aline board with connector and gently plug into mother board.
2. Secure to chassis with two screws, washers and lock washers.
3. Tighten two screws.
4. Close up modem (para 4-11).

4-17. REMOVE/REPLACE MOTHER BOARD

INITIAL SETUP

Common Tools

- Tool kit

Materials/Spare Parts

- Antistatic plastic bags
- Paper
- Pen or pencil

Remove

1. Access modem (para 4-11).
2. Remove circuit boards, A1 thru A8 (para 4-18, Remove step 2).
- 3\* Remove power supply assembly (para 4-12, Remove steps 2-7).
4. Remove input/output board (A9) (para 4-16, Remove steps 2-4).
5. Remove rate/mode display board (para 4-15, Remove steps 3-5).
6. Remove screws. Lift mother board from chassis.
7. Note jumper settings.

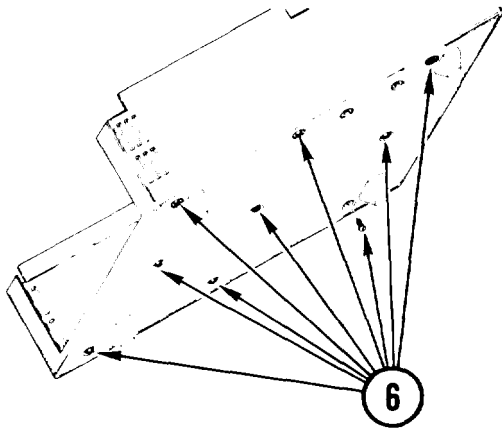

Replace

1. Using your notes, set jumpers.
2. Set mother board in chassis and replace screws.
3. Replace rate/mode display board (para 4-15, Replace steps 1-3).
4. Replace input/output board, (para 4-16, Replace steps 1-3).
5. Replace power supply assembly (para 4-12, Replace steps 1-5).
6. Replace circuit boards in their respective positions (para 4-18).

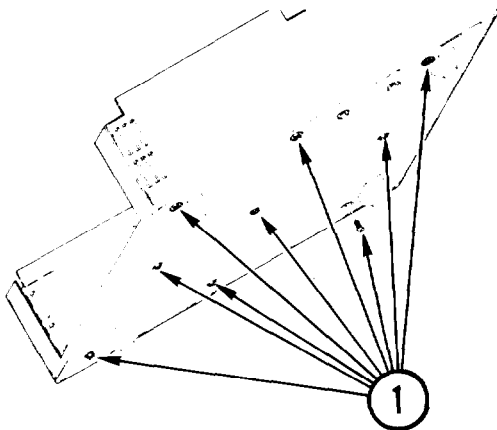



## 4-18. REMOVE/REPLACE CIRCUIT BOARDS A1 THRU A8

## INITIAL SETUP

## Common Tools

- Tool kit

## Materials/Spare Parts

- Antistatic plastic bags

RemoveCAUTION

Circuit board devices are sensitive to static charges and require careful handling. Antistatic bags must be used when stowing these circuit boards.

1. Access modem (para 4-11).
2. Remove circuit board from mother board by unplugging and lifting ear. Stow each in an antistatic plastic bag pending replacement.

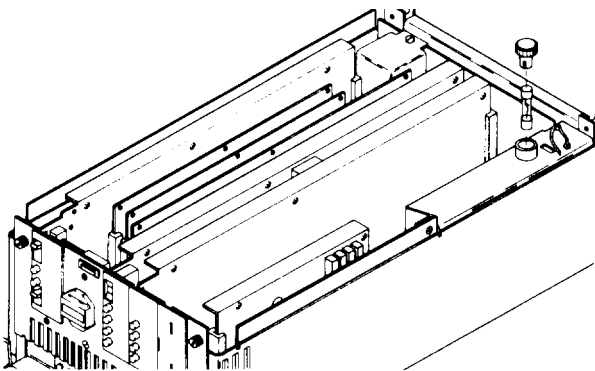
**W**

## NOTE

Each circuit board is identified with a number. Also, these same numbers are used to identify plug-in connectors on mother board. They are also keyed so it is impossible to get a board in the wrong location.

1. Remove board from antistatic bag.
2. Carefully plug board into the respective connector on mother board.
3. Close up modem (para 4-11).

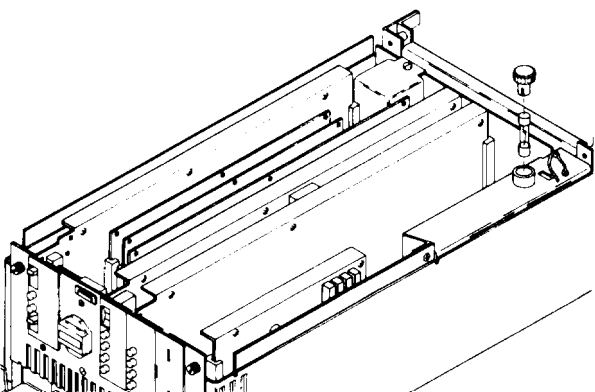



## APPENDIX A

### REFERENCES

#### A-1. INTRODUCTION

This appendix lists all forms, field manuals and technical manuals referenced in, or required for use with, this technical manual.

#### A-2. FORMS

Equipment Inspection and Maintenance Worksheet . . . . .	DA Form 2404
Quality Deficiency Report . . . . .	Form SF 368
Discrepancy in Shipment Report . . . . .	Form SF 364
Recommended Changes to Equipment Technical Manuals . . . . .	DA Form 2028-2
Recommended Changes to Publications and Blank Forms . . . . .	DA Form 2028
Maintenance Request . . . . .	DAForm 2407

#### A-3. TECHNICAL MANUALS

Procedures for Destruction of Electronic Materiel to Prevent Enemy Use (Electronics Command)	TM 750-244-2
The Army Maintenance Management System (TAMMS) : : : : : : : : : : :	TM 38-750
Administrative Storage of Equipment . . . . .	TM 740-90-1

#### A-4. MISCELLANEOUS PUBLICATIONS

Consolidated Index of Army Publications and Blank Forms . . . . .	DA PAM 310-1
---	--------------



## APPENDIX B

### MAINTENANCE ALLOCATION CHART

#### Section 1. INTRODUCTION

##### B-1. GENERAL

This Maintenance Allocation Chart (MAC) provides a summary of maintenance operations for the Modem Unit MD-1149/MYQ-4A. This document assigns categories of maintenance for specific maintenance functions on repairable items and identifies tools and equipment required to perform each function. Each maintenance function is assigned to the lowest level of maintenance prepared to perform that function. It should be understood that each maintenance function can also be performed at all higher levels of maintenance. The higher levels of maintenance will have tools and test equipment to perform the maintenance functions assigned to and normally performed by lower levels of maintenance.

##### B-2. MAINTENANCE FUNCTION DEFINITIONS.

Maintenance Functions are limited to and defined as follows:

- a. Inspect. Determination of the serviceability of an item by comparing its physical, mechanical, and/or electrical characteristics with established standards through examination.
- b. Test. Verification of serviceability and detection of beginning failure by measuring the mechanical or electrical characteristics of an item and comparing those characteristics with prescribed standards.
- c. Service. Performance of operations required periodically to keep an item in proper operating condition. Such operations would include cleaning, preservation, draining, painting, or replenishment of fuel/lubricants/hydraulic fluids or compressed air supplies.
- d. Adjust. Maintenance within prescribed limits by bringing into proper or exact position, or by setting the operating characteristics to the specified parameters.
- e. Align. Adjustment of specified variable elements of an item to the maximum or desired performance.
- f. Calibrate. Determination and cause corrections to or adjustments to instruments or test measuring and diagnostic equipment used in precision measurement. Consists of comparing two instruments, one a certified standard of known accuracy, to detect and adjust any discrepancy in the accuracy of the instrument being compared.
- g. Install. Emplacement, seating, or fixing into position an item, part, or module component or assembly) in a manner to allow proper functioning of the equipment/system.

h. Replace. Substitution of a serviceable like-type part, subassembly, or module (component or assembly) for an unserviceable counterpart.

i. Repair. Application of maintenance services (inspect, test, service, adjust, align, calibrate, replace) or other maintenance actions (welding, grinding, riveting, straightening, facing, remachining, or resurfacing) to restore serviceability to an item by correcting specific damage, fault, malfunction, or failure in a part, subassembly, module/component/assembly, and item or system. This function does not include trial and error replacement of consumable spare type items such as fuses, lamps, or electronic tubes.

j. Overhaul. Periodic maintenance effort (service/action) necessary to restore an item to a completely serviceable/operational condition as prescribed by maintenance standards (e.g., DMWR) in appropriate technical publications. Overhaul is normally the highest degree of maintenance performed by the Army. Overhaul does not normally return an item to like-new condition.

k. Rebuild. Restoration of unserviceable equipment to a like-new condition in accordance with original manufacturing standards. Rebuild is the highest degree of material maintenance applied to Army equipment. The rebuild operation includes the act of returning to zero those age measurements (hour, miles, etc.) considered in classifying Army equipment/components.

### B-3. EXPLANATION OF MAC COLUMN ENTRIES.

This column lists group numbers, the purpose of which is to identify components, assemblies, subassemblies and modules with the next highest assembly.

b. Component/Assembly. This column contains the noun names of components, assemblies, subassemblies, and modules for which maintenance is authorized.

c. Maintenance Function. This column lists the functions to be performed on the item listed in the Component/Assembly column.

d. Maintenance Category. This column specifies, by the listing of a "worktime" figure in the appropriate subcolumn(s), the lowest level of maintenance authorized to perform the function listed in the Maintenance Function column. This figure represents the active time required to perform that maintenance function at the indicated category of maintenance. **If** the number or complexity of the tasks within the listed maintenance function varies at different maintenance categories, appropriate "worktime" figures will be shown for each category. The number of man-hours specified by the "worktime" figure represents the average time required to restore an item (assembly, subassembly, component, module, end item, or system) to a serviceable condition under typical field operating conditions. This time includes preparation time, troubleshooting time, and quality assurance/quality control time in addition to the time required to perform the specific tasks identified for the maintenance functions authorized in the MAC.

Subcolumns of the Maintenance Category column are:

- C -- Operation/Crew
- O -- Organizational
- F -- Direct Support
- H -- General Support
- D -- Depot

e. Tools and Equipment. This column specifies by code those common tool sets (not individual tools) and special tools, test, and supporting equipment required to perform the designated function.

#### B-4. EXPLANATION OF SECTION **III** COLUMN ENTRIES.

a. Tool or Test Equipment Reference Code. The numbers in this column coincide with the numbers used in the tools and equipment column of the MAC. The numbers indicate the applicable tool or test equipment for the maintenance functions.

b. Maintenance Category. The codes in this column indicate the maintenance category allocated the tool or test equipment.

c. Nomenclature. This column lists the noun name and nomenclature of tools and test equipment required to perform the maintenance functions.

d. National/NATO Stock Number. This column presents the National/NATO Stock number of the specific tool or test equipment when these numbers are assigned.

e. Tool Number. This column lists the manufacturer's part number of the tool, followed by the Federal Supply Code for the Manufacturer (5 digit) in parentheses, when these numbers are fully identified.

#### B-5. EXPLANATION OF SECTION **IV** COLUMN ENTRIES.

a. Reference Code. The letters in this column coincide with the letters used in column 6 of the Maintenance Allocation Chart.

b. Remarks. This column lists the remarks which correspond with the reference code letters.

Section II.

MAINTENANCE ALLOCATION CHART

GROUP NUMBER	14 COMPONENT/ ASSEMBLY	12 MAINTENANCE FUNCTION	MAINTENANCE CATEGORY				(5) TOOLS AND EQPT.	(6) REMARKS	
			C	F	H	D			
27	MODEM UNIT	TEST	.0	.0	.5	.0	.0	0001 0002	
		REPLACE	.0	.0	.2	.0	.0	0002	
		REPAIR	.0	.0	.5	.0	.0	0002	
2701	PCB.PMR SPLY RBLTR	OVERHAUL	.0	.0	.0	.0	3.0		A
		TEST	.0	.0	.3	.0	.0	0001 0002	
		REPLACE	.0	.0	.3	.0	.0	0002	
2702	PCB.EIA INTERFACE	OVERHAUL	.0	.0	.0	.0	.8		
		TEST	.0	.0	.3	.0	.0	0002	
		REPLACE	.0	.0	.3	.0	.0	0002	
2703	PCB.CONTROL CARD	OVERHAUL	.0	.0	.0	.0	.8		
		TEST	.0	.0	.2	.0	.0	0002	
		REPLACE	.0	.0	.3	.0	.0	0002	
2704	PCB.RECEIVER	OVERHAUL	.0	.0	.0	.0	.8		
		TEST	.0	.0	.3	.0	.0	0002	
		REPLACE	.0	.0	.3	.0	.0	0002	
2705	PCB.EQUALIZER	OVERHAUL	.0	.0	.0	.0	.8		
		TEST	.0	.0	.4	.0	.0	0002	
		REPLACE	.0	.0	.3	.0	.0	0002	
2706	PCB.TRANSMITTER	OVERHAUL	.0	.0	.0	.0	.8		
		TEST	.0	.0	.3	.0	.0	0002	
		REPLACE	.0	.0	.3	.0	.0	0002	
2707	PCB.REMOTE LOOPBACK	OVERHAUL	.0	.0	.0	.0	.8		
		TEST	.0	.0	.3	.0	.0	0002	
		REPLACE	.0	.0	.3	.0	.0	0002	
2708	PCB.I/O	OVERHAUL	.0	.0	.0	.0	.8		
		TEST	.0	.0	.3	.0	.0	0002	
		REPLACE	.0	.0	.3	.0	.0	0002	
2709	CHASSIS.ELEC EQUIP	OVERHAUL	.0	.0	.0	.0	.8		
		TEST	.0	.0	.2	.0	.0	0002	
		REPLACE	.0	.0	.4	.0	.0	0002	
270901	POWER SUPPLY ASSY	REPAIR	.0	.0	.4	.0	.0	0002	
		TEST	.0	.0	.5	.0	.0	0001 0002	
		REPLACE	.0	.0	.5	.0	.0	0002	
270902	MODULE.DIGIT DISP	OVERHAUL	.0	.0	.0	.0	1.0		A
		TEST	.0	.0	.4	.0	.0	0002	
		REPLACE	.0	.0	.4	.0	.0	0002	
270903	BOARD ASSY.MOTHER	OVERHAUL	.0	.0	.0	.0	1.0		
		TEST	.0	.0	.4	.0	.0	0001 0002	
		REPLACE	.0	.0	.5	.0	.0	0002	
		OVERHAUL	.0	.0	.0	.0	1.0		



Section III.

END ITEM. MD1149/MYQ-4A				
TOOL AND TEST EQUIPMENT REQUIREMENTS (DARCOM-P 750-16)				
TOOL OR TEST EQUIPMENT REFERENCE CODE	MAINTENANCE CATAGORY	NOMENCLATURE	NATIONAL/NATO STOCK NUMBER	1001 NUMBER
0001 0002	F F	MULTIMETER, DIGITAL TOOL KIT, ELECTRONIC	6625-01-139-2512 5180-01-023-4982	AN/PSM-45 JTK-17LMLD

SECTION IV MAINTENANCE ALLOCATION CHART  
FOR MODEM UNIT MD-1149/MYQ-4A

---

Reference Code	Remarks
A.	Overhaul by Contractor

---

# **APPENDIX C EXPENDABLE SUPPLIES AND MATERIALS LIST**

## **Section 1. INTRODUCTION**

### C-1. SCOPE

This appendix lists expendable supplies and materials you are authorized for the support of MODEM UNIT MDI 149/MYQ-4A.

### C-2 . GENERAL

This list identifies items that do not have to accompany MODEM UNIT MDI 149/MYQ-4A and that do not have to be turned in with it.

### C-3. EXPLANATION OF LISTING

National stock numbers, descriptions, and quantities are provided to help you identify and request the additional items you require to support this equipment.

## **Section II. EXPENDABLE SUPPLIES AND MATERIALS**

(NOT APPLICABLE)



## APPENDIX D

### SCHEMATIC DIAGRAMS

#### D-1. GENERAL

The schematic diagram for the V.29 modem power supply is on a foldout page (F0-1) at the back of this manual. It will be helpful if the troubleshooting procedures within this manual fail to help you isolate the fault. With the schematic diagram you can identify points at which to make resistance, continuity, voltage or signal checks that will help you isolate the faulty component. The signal flow of the transmit function is found on (F0-2) and receive function on (F0-3) following the power supply schematic.

<u>Figure</u>	<u>Title</u>
F0-1	Power Supply Schematic
F0-2	Transmitter Block Diagram
F0-3	Receiver Block Diagram



## GLOSSARY

**ANALOG.** When used in telecommunications, means a continuous electrical signal that varies in frequency or amplitude in relation to a digital input. Since digital signals cannot be transmitted over long distances, the modem is used to convert digital signals into analog signals which can be transmitted.

**ASCII.** American Standard Code for Information Interchange. A standard used for transmission of data between computer systems and remote terminals. A coded character set consisting of seven bit characters (eight with parity check).

**ASYNCHRONOUS.** Data communications which is not time related. Uses stop and start bits instead of time pulses to organize data for transmission.

**BAUD.** A unit of measure for data transmission. Indicates the rate of changes in signal over a given period of time.

**DIGITAL.** When used in telecommunications, means a nominally discontinuous signal that changes in frequency, amplitude and polarity.

**DIPSWITCH.** Miniature rocker switch used to select configurations of circuit boards.

**DEDICATED LINES.** Lines assigned to one user only.

**EQUALIZER.** A passive device designed to compensate for an undesired amplitude - frequency and/or phase frequency characteristic of a system or component.

**FALLBACK CAPABILITY.** Ability to change from 9600 to 7200, 4800 or 2400 bps when conditions are not good for the fastest mode.

**FULL DUPLEX.** Communications mode which allows transmission and reception at the same time.

**HALF DUPLEX.** Communications mode which allows transmission and reception but not at the same time.

**MODEM.** Modulator-Demodulator. A device which converts digital data to analog form so it can be transmitted. Also receives analog form and converts it to digital data.

**QUADRATURE.** Modulation of two carrier components 90° apart in phase by separate modulating functions.

**TRAINING.** The method of communication synchronization necessary between transmitter and receiver functions of two modems to lock in the flow before data transmission is possible.

**SYNCHRONOUS.** Data communications which operate at one baud rate and does not need stop and start bits for transmission.





# INDEX

SUBJECT	A	PARAGRAPH
Access/Close Up V. 29 Modem . . . . .		4-11
Administrative Storage . . . . .		1-5
Alternative Troubleshooting Techniques . . . . .		4-6
C		
Check/Adjust Power Supply Voltage . . . . .		4-13
Checking Unpacked Equipment . . . . .		3-5
Common Tools and Equipment . . . . .		3-1
Common Tools and Equipment. . . . .		4-1
Controls and Indicators . . . . .		2-3
D		
Destruction of Army Electronics Materiel . . . . .		1-4
E		
Equipment Configuration . . . . .		1-15
Equipment Data . . . . .		1-14
Equipment Handling Precautions . . . . .		4-9
Equipment Identification Plate . . . . .		1-13
Equipment Purpose, Capabilities and Features . . . . .		1-11
Equipment Will Be Reported Not Ready/Available If Column . . . . .		3-11
F		
Functional Description . . . . .		2-4
G		
Glossary . . . . .		Glossary-1
I		
Index of Publications. . . . .		1-2
Item Number Column . . . . .		3-8
Item to be Inspected Column . . . . .		3-9
L		
List of Abbreviations. . . . .		1-9
Location and Description of Major Components . . . . .		1-12
M		
Maintenance Forms, Records, and Reports . . . . .		1-3
Maintenance Procedures . . . . .		4-10
Modem Assembly Mounting Options . . . . .		1-16

INDEX (CONT)

SUBJECT	M (Cent)	PARAGRAPH
Modem Board Jumper Options . . . . .		1-18
Mul ti poi nt Confi gurati on . . . . .		2-10
N		
Nomenclature Cross Reference Li st . . . . .		1-8
O		
Operati ng Pri nci pl es . . . . .		2-2
P		
PMCS Procedures. . . . .		3-7
Power Options. . . . .		1-17
Power Supply and Power Di stri buti on . . . . .		2-5
Procedure Col umn . . . . .		3-10
R		
Recei vi ng Functi on . . . . .		2-8
Reference Informati on . . . . .		1-7
Regul ators . . . . .		2-6
Remove/Repl ace Ci rcui t Board; A1 thru A8 . . . . .		4-18
Remove/Repl ace Input/Output Board . . . . .		4-16
Remove/Repl ace Fuse. . . . .		4-14
Remove/Repl ace Mother Board . . . . .		4-17
Remove/Repl ace Power Supply Assembl y . . . . .		4-12
Remove/Repl ace Rate/Mode Di spl ay Board . . . . .		4-15
Reporti ng Equi pment Improveme nt Recommendati ons (EIR) . . . . .		1-6
Run Sel f Test. . . . .		3-12
S		
Scope. . . . .		1-1
Self Test and Fault Isolati on . . . . .		2-11
Spares and Repair Parts . . . . .		3-3
Spares and Repair Parts . . . . .		4-3
Special Tools, TMDE, and Support Equi pment . . . . .		3-2
Special Tools, TMDE, and Support Equi pment . . . . .		4-2
System Test and Fault Isolati on . . . . .		2-11
T		
Transmi tti ng Functi on . . . . .		2-7
Troubl eshooti ng Phases. . . . .		4-5
Troubl eshooti ng Procedures . . . . .		4-7

I N D E X ( C O N T )

SUBJECT	u	PARAGRAPH
Unattended Remote Loopback . . . . .		2-9
Unpacki ng. . . . .		3-4



RECOMMENDED CHANGES TO EQUIPMENT TECHNICAL PUBLICATIONS



THEN JOT DOWN THE DOPE ABOUT IT ON THIS FORM. CAREFULLY TEAR IT OUT, FOLD IT AND DROP IT IN THE MAIL.

SOMETHING WRONG WITH THIS PUBLICATION?

FROM: PRINT YOUR UNIT'S COMPLETE ADDRESS  
 Commander  
 Stateside Army Depot  
 ATTN: AMSTA-US  
 Stateside, N.J. 07703

DATE SENT: 10 July 1975

PUBLICATION NUMBER: TM 11-5840-340-12  
 PUBLICATION DATE: 23 Jan 74  
 PUBLICATION TITLE: Radar Set AN/PRC-76

BE EXACT - PIN-POINT WHERE IT IS				IN THIS SPACE TELL WHAT IS WRONG AND WHAT SHOULD BE DONE ABOUT IT:
PAGE NO	PARA. GRAPH	FIGURE NO	TABLE NO	
2-25	2-28			<p>Recommend that the installation antenna alignment procedure be changed throughout to specify a 2° IFF antenna lag rather than 1°</p> <p>REASON: Experience has shown that with only a 1° lag, the antenna servo system is too sensitive to wind gusting in excess of 25 knots, and has a tendency to rapidly accelerate and decelerate as it hunts, causing strain to the drive train. Hunting is minimized by adjusting the lag to 2° without degradation of operation.</p>
3-10	3-5		3-1	<p>Item 5, Function column. Change "2 db" to "5db."</p> <p>REASON: The adjustment procedure the the TRANS POWER FAULT indicator calls for a 5 db (500 watts) adjustment to light the TRANS POWER FAULT indicator.</p>
5-6	5-8			<p>Add new step f.1 to read, "Replace cover plate removed in step e.1, above."</p> <p>REASON: To replace the cover plate.</p>
		F03		<p>Zone C 3. On J1-2, change "+24 VDC to "+5 VDC."</p> <p>REASON: This is the output line of the 5 VDC power supply. +24 VDC is the input voltage.</p>

PRINTED NAME GRADE OR TITLE AND TELEPHONE NUMBER  
 SSG I. M. DeSpirito 999-1776

SIGN HERE

DA FORM 2028-2 JUL 79

PREVIOUS EDITIONS ARE OBSOLETE

PS - IF YOUR OUTLET WANTS TO KNOW ABOUT YOUR RECOMMENDATION MAKE A CARBON COPY OF THIS AND GIVE IT TO YOUR HEADQUARTERS

FILL IN YOUR  
UNIT'S ADDRESS

FOLD BACK

DEPARTMENT OF THE ARMY

OFFICIAL BUSINESS  
PENALTY FOR PRIVATE USE \$300

POSTAGE AND FEES PAID  
DEPARTMENT OF THE ARMY  
DOD 314



TEAR ALONG PERFORATED LINE

Commander  
US Army Communications-Electronics Command  
and Fort Monmouth  
ATTN: DRSEL-ME-MP  
Fort Monmouth, New Jersey 07703

RECOMMENDED CHANGES TO EQUIPMENT TECHNICAL PUBLICATIONS



**SOMETHING WRONG** WITH THIS PUBLICATION?

*THEN...JOT DOWN THE DOPE ABOUT IT ON THIS FORM. CAREFULLY TEAR IT OUT, FOLD IT AND DROP IT IN THE MAIL.*

FROM: (PRINT YOUR UNIT'S COMPLETE ADDRESS)

DATE SENT

PUBLICATION NUMBER

TM 11-7025-234-23

PUBLICATION DATE

2 May 85

PUBLICATION TITLE

Modem Unit MD-1149/MYQ-4A

BE EXACT PIN-POINT WHERE IT IS

PAGE NO.

PARA-GRAPH

FIGURE NO.

TABLE NO.

IN THIS SPACE TELL WHAT IS WRONG AND WHAT SHOULD BE DONE ABOUT IT:

TEAR ALONG PERFORATED LINE

PRINTED NAME GRADE OR TITLE AND TELEPHONE NUMBER

SIGN HERE

DA FORM 2028-2  
1 JUL 79

PREVIOUS EDITIONS ARE OBSOLETE

P.S.--IF YOUR OUTFIT WANTS TO KNOW ABOUT YOUR RECOMMENDATION MAKE A CARBON COPY OF THIS AND GIVE IT TO YOUR HEADQUARTERS.

FILL IN YOUR  
UNIT'S ADDRESS

FOLD BACK

DEPARTMENT OF THE ARMY

\_\_\_\_\_  
\_\_\_\_\_

OFFICIAL BUSINESS  
PENALTY FOR PRIVATE USE \$300

POSTAGE AND FEES PAID  
DEPARTMENT OF THE ARMY  
DOD 314



TEAR ALONG PERFORATED LINE

Commander  
US Army Communications-Electronics Command  
and Fort Monmouth  
ATTN: DRSEL-ME-MP  
Fort Monmouth, New Jersey 07703



RECOMMENDED CHANGES TO EQUIPMENT TECHNICAL PUBLICATIONS



**SOMETHING WRONG WITH THIS PUBLICATION?**

*THEN...JOT DOWN THE DOPE ABOUT IT ON THIS FORM. CAREFULLY TEAR IT OUT, FOLD IT AND DROP IT IN THE MAIL.*

FROM: (PRINT YOUR UNIT'S COMPLETE ADDRESS)

DATE SENT

PUBLICATION NUMBER

TM 11-7025-234-23

PUBLICATION DATE

2 May 85

PUBLICATION TITLE

Modem Unit MD-1149/MYQ-4A

BE EXACT PIN-POINT WHERE IT IS

PAGE NO.	PARA-GRAPH	FIGURE NO.	TABLE NO.

IN THIS SPACE TELL WHAT IS WRONG AND WHAT SHOULD BE DONE ABOUT IT:

TEAR ALONG PERFORATED LINE

PRINTED NAME GRADE OR TITLE AND TELEPHONE NUMBER

SIGN HERE

DA FORM 2028-2  
JUL 79

PREVIOUS EDITIONS ARE OBSOLETE

P.S...IF YOUR OUTFIT WANTS TO KNOW ABOUT YOUR RECOMMENDATION MAKE A CARBON COPY OF THIS AND GIVE IT TO YOUR HEADQUARTERS.

FILL IN YOUR  
UNIT'S ADDRESS

FOLD BACK

DEPARTMENT OF THE ARMY

\_\_\_\_\_  
\_\_\_\_\_

OFFICIAL BUSINESS  
PENALTY FOR PRIVATE USE \$300

POSTAGE AND FEES PAID  
DEPARTMENT OF THE ARMY  
DOD 314



TEAR ALONG PERFORATED LINE

Commander  
US Army Communications-Electronics Command  
and Fort Monmouth  
ATTN: DRSEL-ME-MP  
Fort Monmouth, New Jersey 07703

RECOMMENDED CHANGES TO EQUIPMENT TECHNICAL PUBLICATIONS



THEN...JOT DOWN THE DOPE ABOUT IT ON THIS FORM. CAREFULLY TEAR IT OUT, FOLD IT AND DROP IT IN THE MAIL.

**SOMETHING WRONG WITH THIS PUBLICATION?**

FROM: (PRINT YOUR UNIT'S COMPLETE ADDRESS)

DATE SENT

PUBLICATION NUMBER

TM 11-7025-234-23

PUBLICATION DATE

2 May 85

PUBLICATION TITLE

Modem Unit MD-1149/MYQ-4A

BE EXACT PIN-POINT WHERE IT IS

PAGE NO.	PARA-GRAPH	FIGURE NO.	TABLE NO.

IN THIS SPACE TELL WHAT IS WRONG AND WHAT SHOULD BE DONE ABOUT IT:

TEAR ALONG PERFORATED LINE

PRINTED NAME GRADE OR TITLE AND TELEPHONE NUMBER

SIGN HERE

DA FORM 1, JUL 79 2028-2

PREVIOUS EDITIONS ARE OBSOLETE

P.S.--IF YOUR OUTFIT WANTS TO KNOW ABOUT YOUR RECOMMENDATION MAKE A CARBON COPY OF THIS AND GIVE IT TO YOUR HEADQUARTERS.

FILL IN YOUR  
UNIT'S ADDRESS

FOLD BACK

DEPARTMENT OF THE ARMY

\_\_\_\_\_  
\_\_\_\_\_

OFFICIAL BUSINESS  
PENALTY FOR PRIVATE USE \$300

POSTAGE AND FEES PAID  
DEPARTMENT OF THE ARMY  
DOD 314



TEAR ALONG PERFORATED LINE

Commander  
US Army Communications-Electronics Command  
and Fort Monmouth  
ATTN: DRSEL-ME-MP  
Fort Monmouth, New Jersey 07703

By Order of the Secretary of the Army:

Official:

JOHN A. WICKHAM JR.  
*General, United States Army*  
*Chief of Staff*

DONALD J. DELANDRO  
*Brigadier General, United States Army*  
*The Adjutant General*

**DISTRIBUTION:**

To be distributed in accordance with DA Form 12-51 requirements for DAS3 DIV/CORPS AN/MYQ-4(A).



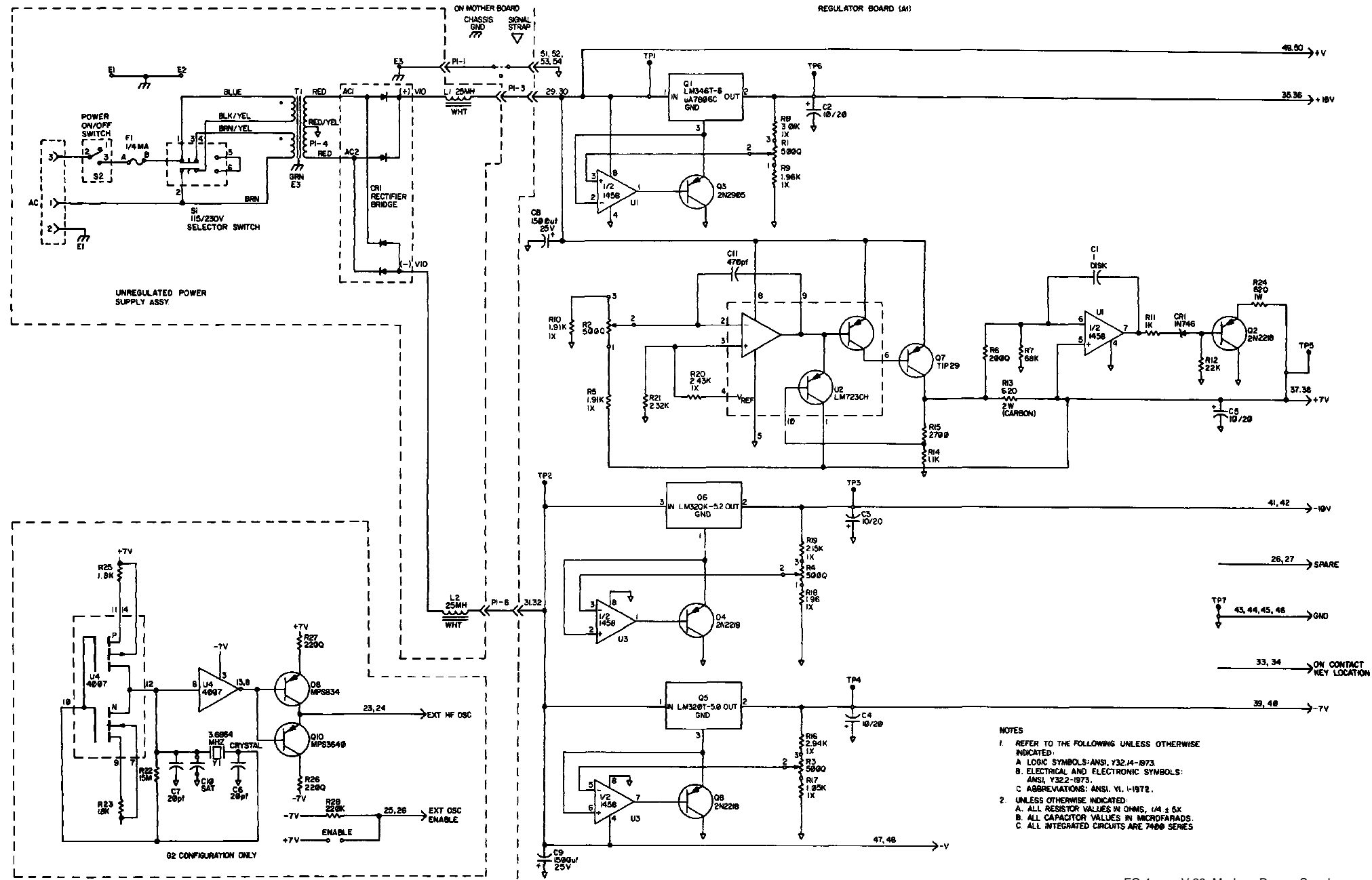

NOTES  
 1. REFER TO THE FOLLOWING UNLESS OTHERWISE INDICATED:  
 A. LOGIC SYMBOLS: ANSI, Y32.14-1973.  
 B. ELECTRICAL AND ELECTRONIC SYMBOLS: ANSI, Y32.1-1973.  
 C. ABBREVIATIONS: ANSI, Y1.1-1972.  
 2. UNLESS OTHERWISE INDICATED:  
 A. ALL RESISTOR VALUES IN OHMS, U4 ± 5K.  
 B. ALL CAPACITOR VALUES IN MICROFARADS.  
 C. ALL INTEGRATED CIRCUITS ARE 7400 SERIES.

FO-1: V.29 Modem Power Supply Schematic

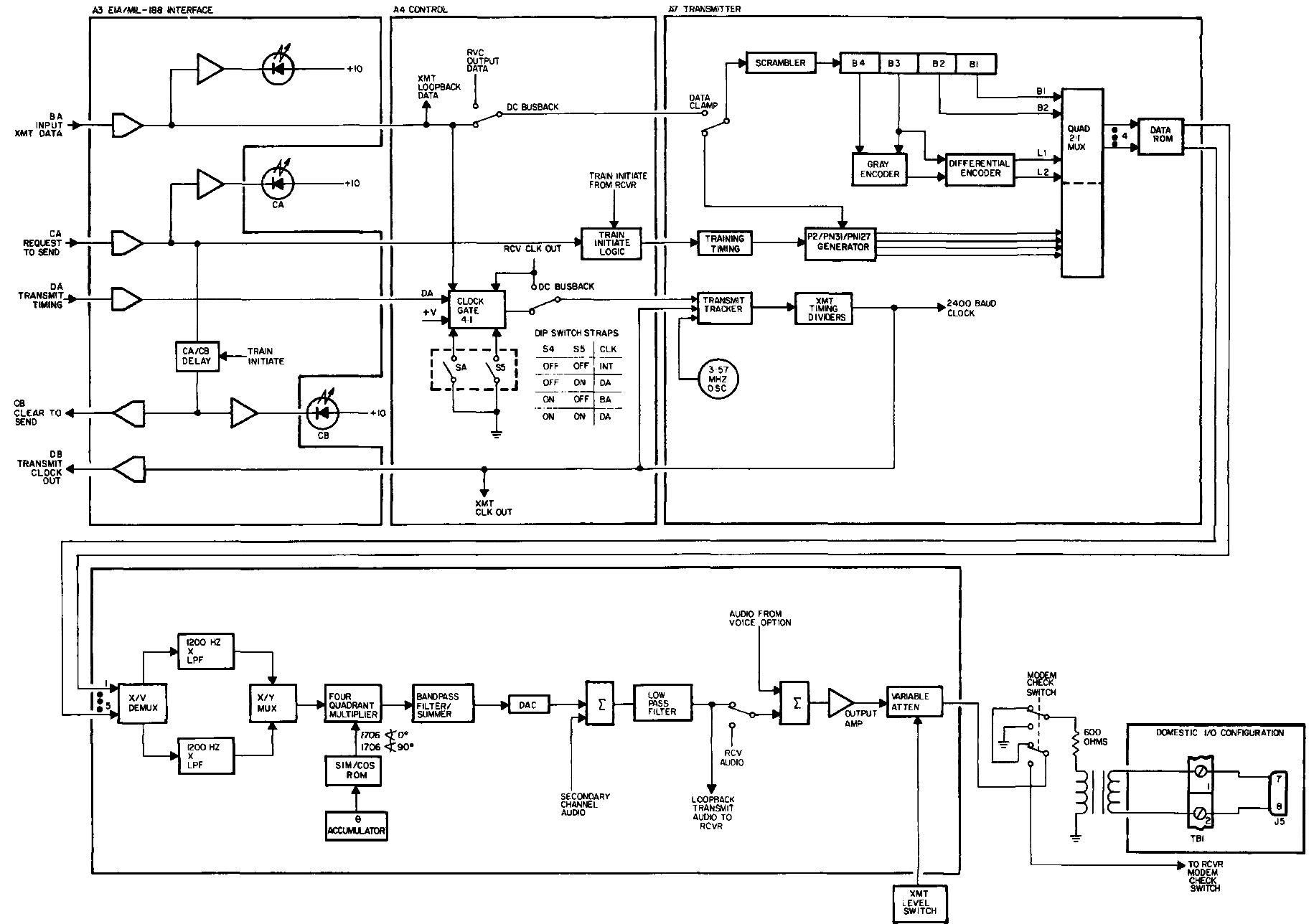

FO-2: Transmitter Block Diagram



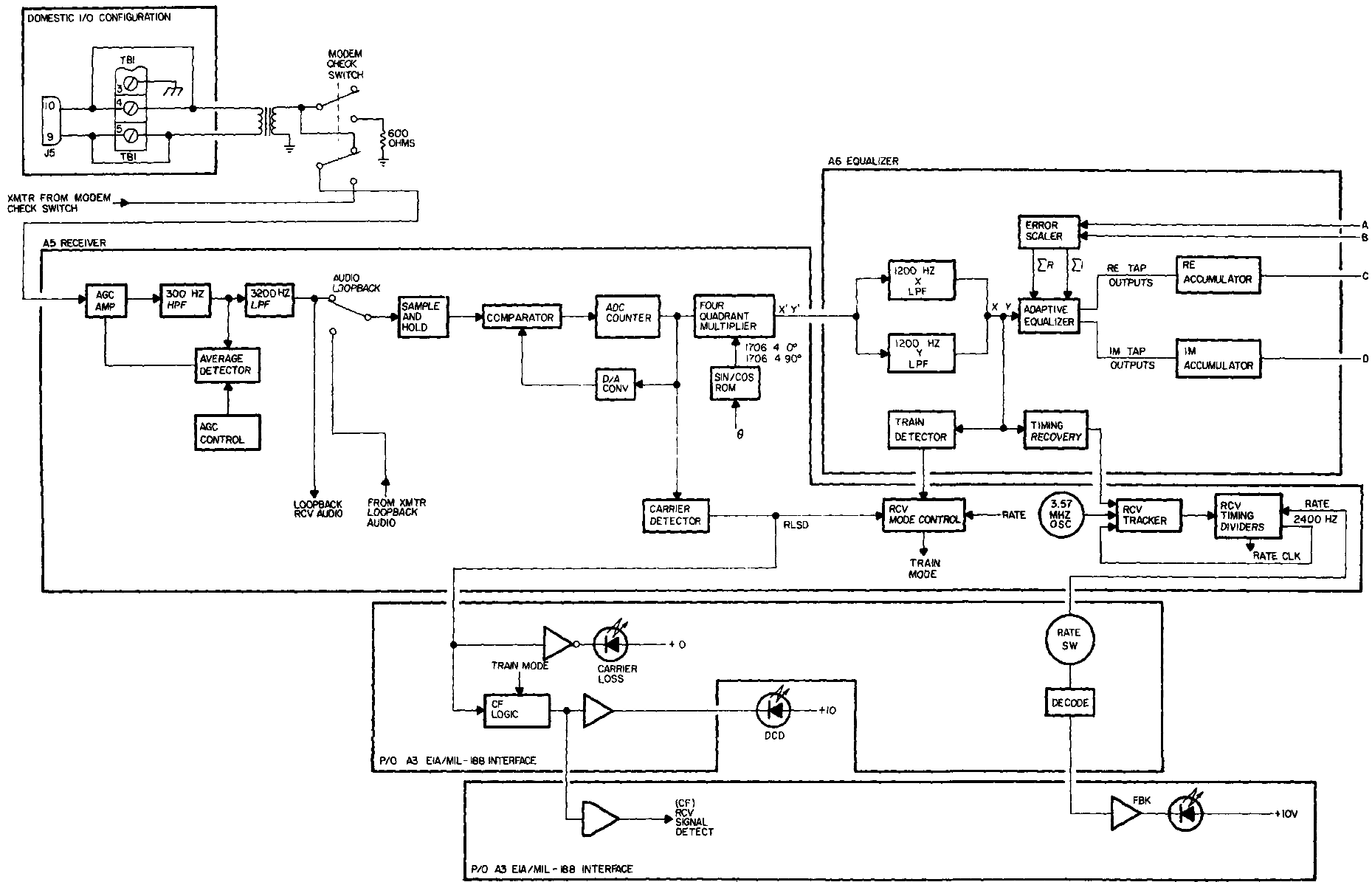

FO-3: Receiver Block Diagram (1 of 2)

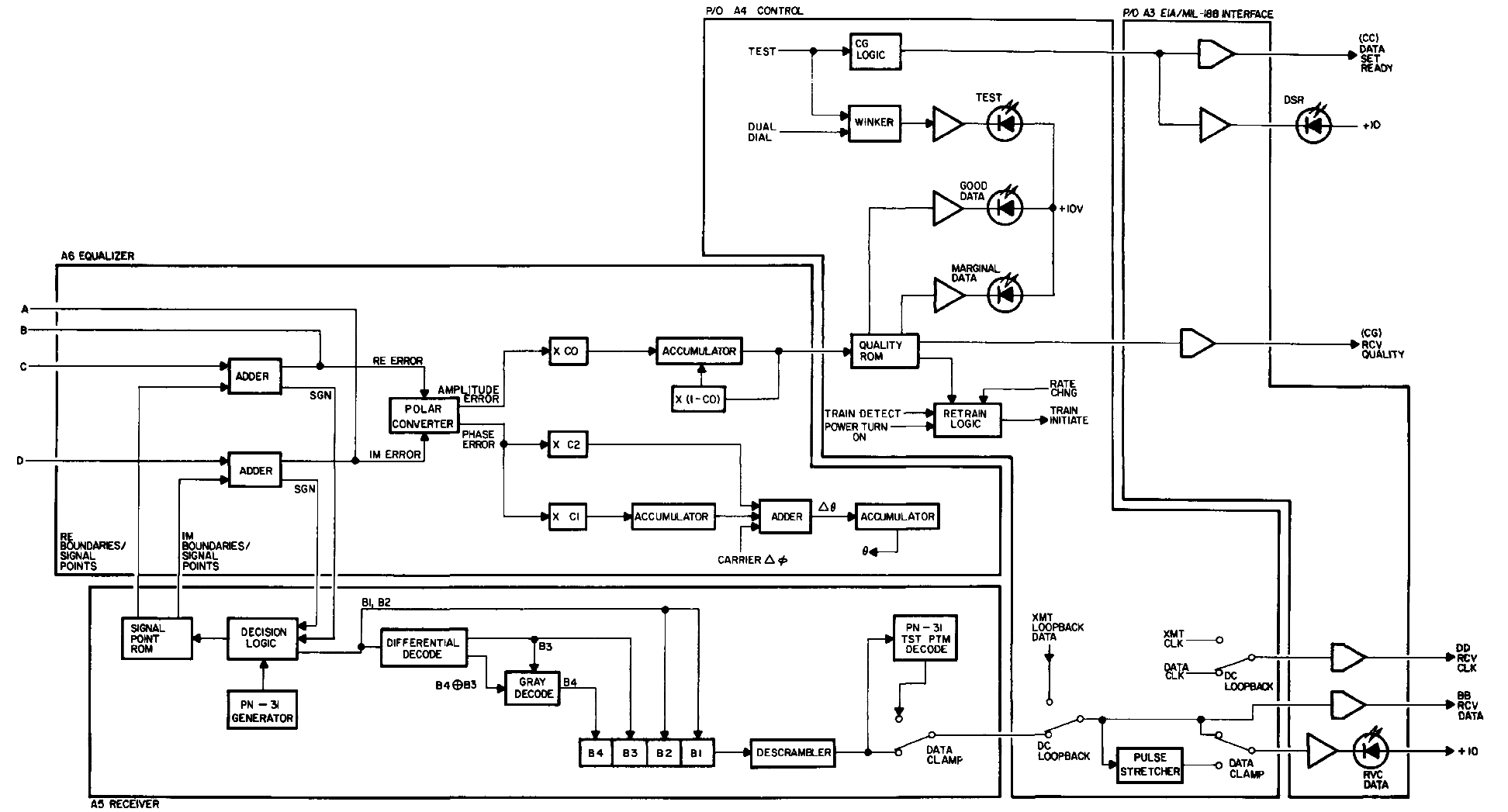



DEPARTMENT OF THE ARMY  
US ARMY AG PUBLICATIONS CENTER  
1655 WOODSON ROAD  
ST. LOUIS, MISSOURI 63114

OFFICIAL BUSINESS  
PENALTY FOR PRIVATE USE, \$300

POSTAGE AND FEES PAID  
DEPARTMENT OF THE ARMY

G-5  
SPECIAL FOURTH  
CLASS RATE ECKS

COMMANDER  
USAMC MAT RDNS SPT ACTV  
ATTN AMXPC-MP  
LEXINGTON KY 40511

M0497

DA PUBLICATION/FORM NUMBER				CHG OR DATE	
TM 11-7025-234-23					
LOCATION	QUANTITY	UNIT OF ISSUE	ACTION	RON DATE	
G0243	1	EA		5227	
PKG SIZE	ITEM NO.	BULK/Rcpt DATE	SLAGPC CONTROL NO.		
	365455	BLK5228	5231	03764	

TAGO FORM 4-26a, 1 SEP 76

PREVIOUS EDITION OF THIS FORM IS OBSOLETE

1590  
11-7025-234-23  
M0497